

# frequently asked questions

## Type 1 and 2 Hydraulic Ram 'Bleeding'

### "How do I bleed the air from my blue hydraulic ram"

Before starting, ensure that the area that the unit is to be serviced in is clean and free of dirt. Take great care at all times to avoid damage to all components and clean them only in non-petroleum based degreasers. Use a vice with protective jaws and clamp only where indicated.

#### Tools required:

The use of the B&G filling kit is highly recommended when performing this procedure.

#### Procedure:

1. Disconnect the ram assembly from the electrical power supply and remove the assembly to a suitable location.
2. Undo and remove the filler plug and withdraw the reservoir assembly from the unit.



**FILLER PLUG**



**RESERVOIR VALVE ASSEMBLY**

3. Screw the tap assembly into the check valve housing. Ensure the tap is "on".
4. Mount the unit vertically in a vice, holding only on the end cap.
5. Plug in the filling kit and fill with oil.
6. Slowly extend the rod to full stroke, wait for a few seconds, and then fully retract it again. Note, the air being expelled from the unit into the plastic reservoir bottle. Repeat this procedure until no air can be observed in the oil.
7. Note also that it will be necessary to top up the oil during filling.
8. Once the unit is bled, fully retract the rod.
9. Turn the tap to the "off" position, and then fully extend the rod.
10. Unplug the filling kit.

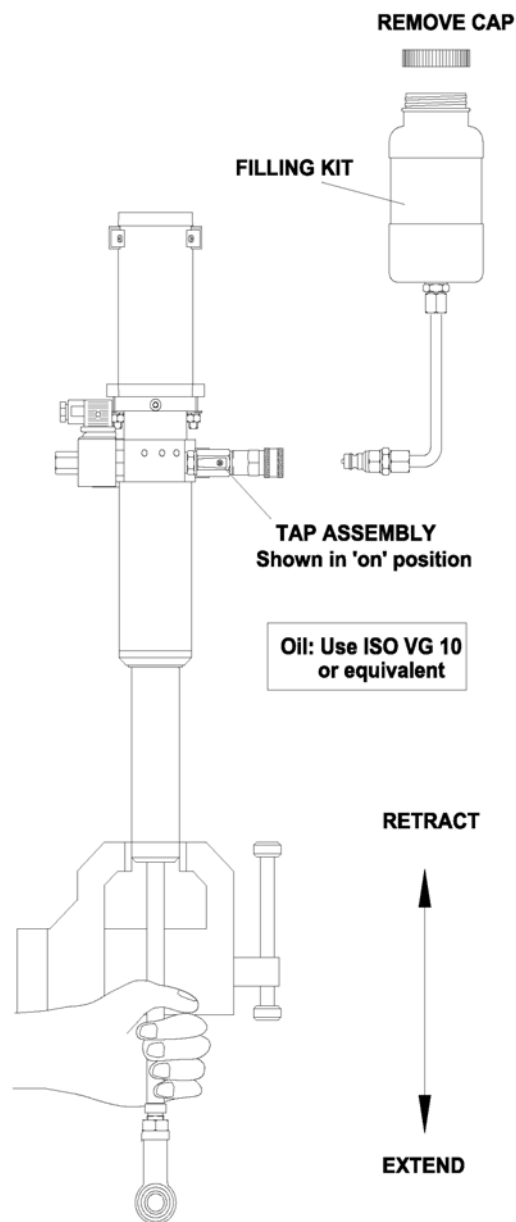

## frequently asked questions

11. Mount the unit horizontally in the vice.
12. Hold only by the pump flange as shown, using only enough pressure on the vice to hold the unit steady.
  - Do **NOT** hold on either the motor or cylinder casings
13. Plug in the measure and fill with 50cc of oil. Turn the tap “on” and observe the amount of oil drawn into the unit.
14. Slowly retract the rod until this amount, plus a further 20cc, are expelled into the measure.
15. Unplug and remove the measure, then remove the tap assembly.
16. Fit the reservoir valve assembly, followed by the plug and bonded seal.
17. With the unit at mid-stroke, connect the coil to a 12V or 24V dc power supply as appropriate. With the coil energised there should be not more than 1mm of movement in the rod. If the movement exceeds this amount, then repeat the procedure.

