

# ***HS 2000***

## **V9**

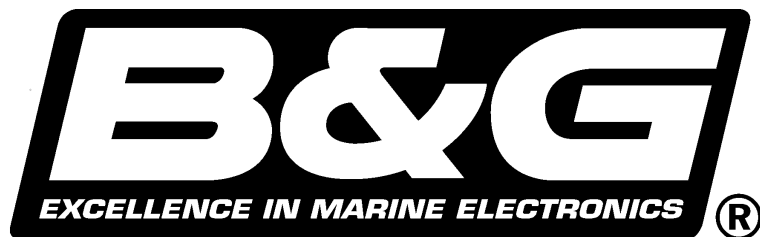

# **USER MANUAL**

Premier Way, Abbey Park  
Romsey, Hampshire, S051 9DH  
England

Tel: (+44) 01794 518448  
Fax: (+44) 01794 518077  
[www.BandG.com](http://www.BandG.com)

© Brookes & Gatehouse Ltd. 2000  
The copyright of this Manual is the property of Brookes & Gatehouse Ltd.

HB-0846-03

# ***HS 2000***

## **USER MANUAL**

### **CONTENTS**

Product Liability and Safety Warnings

Record of Amendments

PART 1 - INTRODUCTION

PART 2 - OPERATING INFORMATION

PART 3 - CALIBRATION

PART 4 - INSTALLATION INFORMATION

PART 5 - OPTIONS

PART 6 - DIAGNOSTIC DATA

APPENDIX 1 CALIBRATION DATA

## **PRODUCT LIABILITY AND SAFETY WARNINGS**

**PRODUCT LIABILITY** - Brookes and Gatehouse Ltd. accept no responsibility for the use and/or operation of this equipment. It is the user's responsibility to ensure that under all circumstances the equipment is used for the purposes for which it has been designed.

**WARNING - ELECTRICAL HAZARD.** This equipment uses high voltage electrical power. Contact with high voltages may result in injury and/or loss of life.

**WARNING - CALIBRATION.** The safe operation of this equipment is dependent on accurate and correct calibration. Incorrect calibration of this equipment may lead to false and inaccurate navigational readings placing the vessel into danger.

**WARNING - NAVIGATION HAZARD.** The HS 2000 is an Electronic Navigation System and is designed to assist in the navigation of your boat. It is not designed to totally replace conventional navigation procedures and precautions and all necessary precautions should be taken to ensure that the boat is not placed into danger.

**CAUTION** - This equipment is designed for use with a power supply source of 12v dc. The application of any other power supply may result in permanent damage to the equipment.



## PART 1 - INTRODUCTION

### CONTENTS

<b>Para</b>		<b>Page</b>
1.1	SYSTEM DESCRIPTION	1-3
1.2	PROCESSORS	1-3
1.2.1	Main Processor Unit	1-3
1.3	SENSORS	1-4
1.3.1	Paddle-Wheel	1-4
1.3.2	XTL Fin Sonic Transducers	1-4
1.3.3	Super Halcyon 3 Fluxgate Compass	1-5
1.3.4	Halcyon 2000 Fluxgate Compass	1-5
1.3.5	Depth Sensor	1-5
1.4	DISPLAYS	1-5
1.4.1	NMEA Full Function Display (FFD)	1-5
1.4.2	Standard Full Function Display (FFD)	1-6
1.4.3	20/20 Display	1-6
1.5	CALIBRATION	1-6
1.6	DAMPING	1-6
1.7	MENU STRUCTURE	1-7

### ILLUSTRATIONS

<b>Fig No</b>		<b>Page</b>
1.1	Typical HS 2000 System Block Diagram	1-2
1.2	XTL Fin Sonic Transducers	1-4

### TABLES

<b>Table No</b>		<b>Page</b>
1.1	Function Menu Choices	1-8
1.2	Operational Menu Choices	1-9

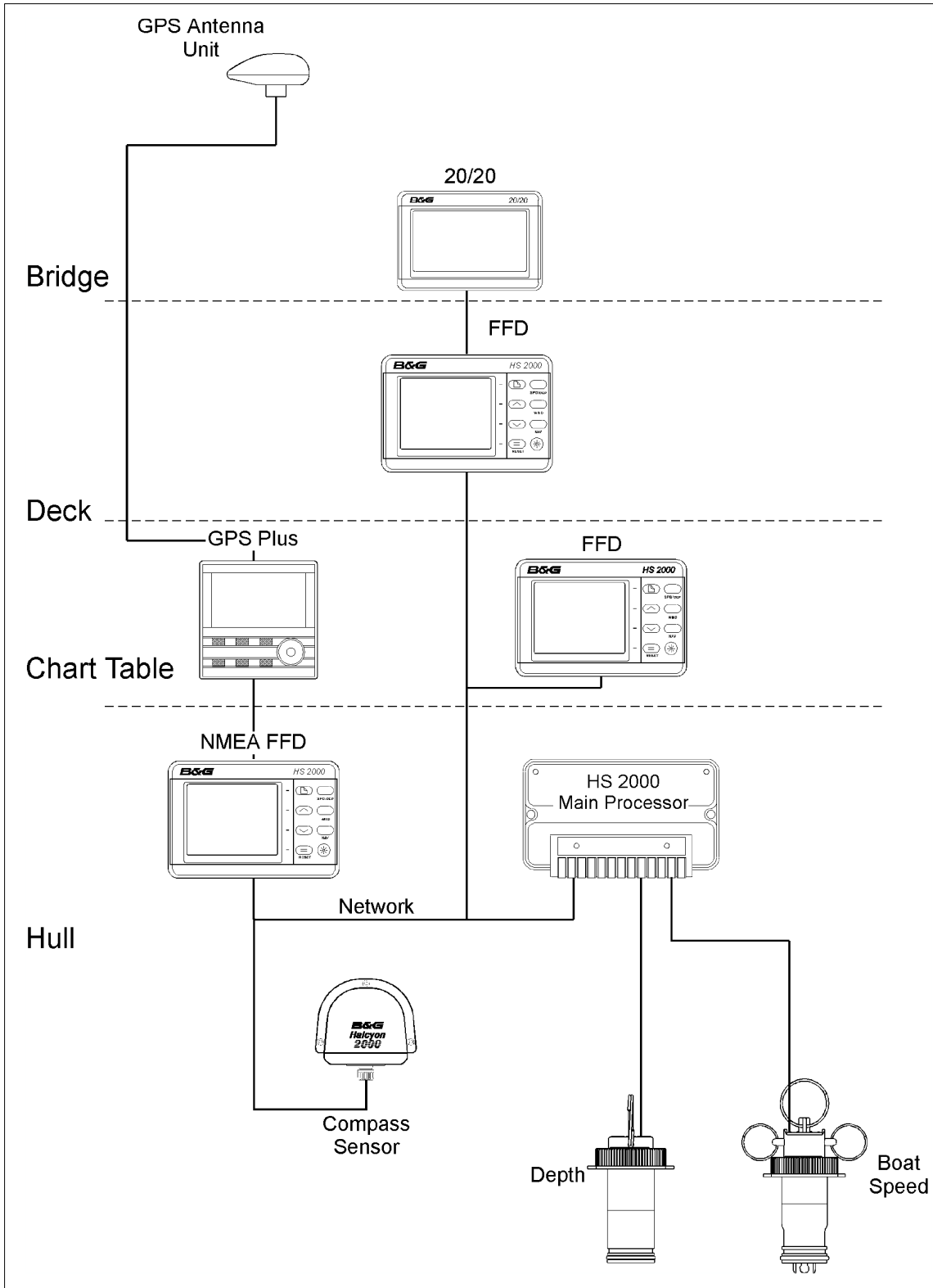

Fig 1.1 - Typical HS 2000 System Block Diagram

## **PART 1 - INTRODUCTION**

### **1.1 SYSTEM DESCRIPTION**

The HS 2000 is a fully integrated power boat instrumentation system that displays information obtained from various sensors on a choice of displays positioned throughout the boat. Information is fed from the sensors to a Main Processor via a high speed communications network. From the information gathered by the sensors the Main Processor distributes information to the various displays, and can carry out a wide range of functions such as boat speed, trip log, depth, sea temperature and tidal information. These functions are controlled from a Full Function Display (FFD).

A typical system is shown in Figure 1.1 - Typical HS 2000 System Block Diagram.

### **1.2 PROCESSORS**

#### **1.2.1 Main Processor Unit**

The Main Processor Unit is the heart of the system and is responsible for monitoring the data from the sensors. The sensors measure the following:

- Depth
- Boat Speed/Log
- Compass Heading
- Sea Temperature

From this information the Main Processor Unit is then able to calculate the following additional functions:

- Average Boat Speed
- Bearing to Waypoint
- Bearing Waypoint to Waypoint
- Course Over Ground
- Dead Reckoned Course and Distance
- Distance to Waypoint
- Next Waypoint Distance
- Speed Over Ground
- Stored Log
- Time to Waypoint
- Trip Log

Once this information is calculated, it is distributed to the displays via the communications network.

The Main Processor Unit contains the battery backed memory that stores all calibration, damping and alarm settings while the power is OFF; these are adjustable from any FFD.

## 1.3 SENSORS

### 1.3.1 Paddle-Wheel

The Paddle-Wheel Speed Sensor is designed primarily for cruising boats and consists of a paddle-wheel which protrudes through the hull via a hull-housing. So that the paddle-wheel may be cleaned at regular intervals, the housing is provided with a flap valve which closes automatically when the unit is withdrawn into the boat.

### 1.3.2 XTL Fin Sonic Transducers

The XTL Sonic Speed<sup>?</sup> Transducer provides an accurate and safe measurement of speed, distance travelled and depth, essential for basic navigation and dead reckoning.

The XTL Sonic Speed<sup>?</sup> System operates on the Doppler principle by measuring the speed of water travelling between the two Sonic Speed Transducers and comparing the signals in the XTL Microsonic control box. Display of linear speed readings up to 35 knots and accurate, stable depth information at high speed, ensure safety in all depths of water.

The single, one piece transducer is bolted to the bottom of the boat and has minimal protrusion inside the boat. The one piece transducer is hydrodynamically designed to offer minimum drag and if damaged does not threaten the water-tight integrity of the boat.

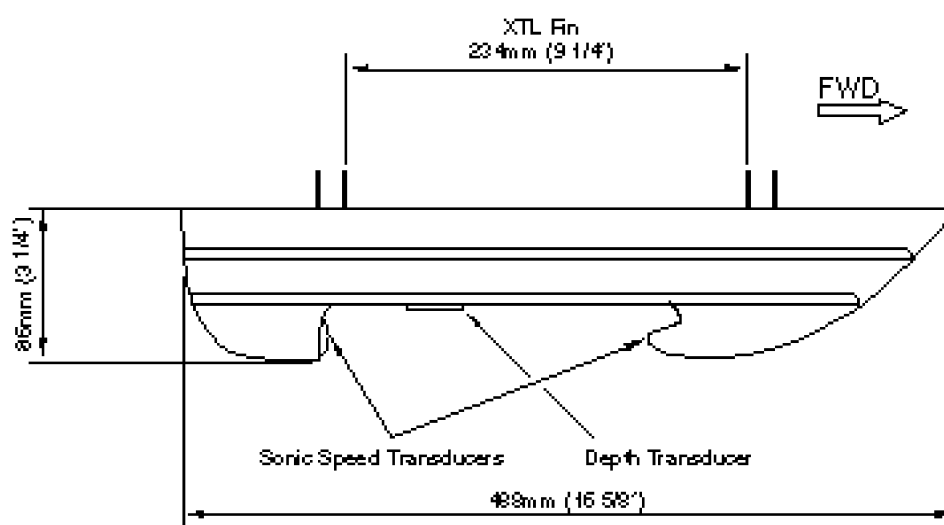

Fig 1.2 XTL Fin Sonic Transducers

### **1.3.3 Super Halcyon 3 Fluxgate Compass**

This fluxgate compass sensor is fully gimballed in a bath of oil, ensuring accurate readings at all normal angles of heel and pitch.

### **1.3.4 Halcyon 2000 Fluxgate Compass**

The Halcyon 2000 Compass is a high performance electronic fluxgate compass for use on power craft. It has been designed specifically to connect directly onto the proprietary B&G high speed databus, thus ensuring fast updates and accurate information.

The Halcyon 2000 Compass has the ability to 'learn' the magnetic effects of the vessel on the compass and automatically apply deviation correction.

### **1.3.5 Depth Sensor**

This can either be a removable through-hull unit, moulded inside the hull for reduced drag, or part of an XTL Fin assembly. The depth datum can be offset to display information from the transducer, water-line or below the keel.

## **1.4 DISPLAYS**

### **1.4.1 NMEA Full Function Display (FFD)**

NMEA is the National Marine Electronics Association, a body which produces standard specifications for the interconnection of marine electronic instruments. These standards specify the electrical signals and the format of the data to be transferred.

The standard system display is the Full Function Display and all HS 2000 Systems require at least one NMEA FFD for interfacing. The other display types described in this Section are options with which the system can be expanded. The FFD is the terminal for the whole system, allowing control of operational, testing and calibration functions.

The FFD displays two functions and descriptive text at any one time. Any system function can be called up on any FFD, and up to 24 FFDs can be connected in the HS 2000 System from which all functions can be operated.

Part 2 - Operating Information describes in detail the use of the FFD keyboard to control the HS 2000.

The NMEA FFD contains an NMEA interface which enables the HS 2000 to connect to other sensor devices such as position fixers, autopilots, track plotters and radars provided by other manufacturers. For example, information from the *GPSplus* can be transferred from the bridge to a steering position above decks. The HS 2000 can also provide information to other instruments; speed and heading for example can be output to radars, chart plotters and other navigational devices provided the instruments are NMEA compatible.

Two further display types can be added to the system, these are:

Standard FFD  
20/20 Display

#### **1.4.2 Standard Full Function Display (FFD)**

The Standard FFD is identical in operation and appearance to the NMEA FFD. The only difference is that the Standard FFD does not have an NMEA interface installed.

#### **1.4.3 20/20 Display**

The HS 2000 20/20 Display is a lightweight, large digit, liquid crystal display and can be configured from any FFD or a remote button to display system information.

The 20/20's operation is fully explained in Part 5 - Options.

### **1.5 CALIBRATION**

Before using the HS 2000 for navigational purposes, it is important that the system is calibrated for your installation. The HS 2000 calibration process has been simplified as far as possible, so that all you require for accurate instrument data is a little background knowledge and the application of a few simple techniques. These are fully explained in Part 3 - Calibration.

### **1.6 DAMPING**

A useful feature is that the damping on most functions is user adjustable. This allows the response of the function to be slowed if it is too jumpy in rough weather, and similarly the response can be quickened when in flat water. The damping operates by averaging the numbers over a time period - the more you increase this time period the smoother the data readings will be, but the longer it will take to view the effect of any change; similarly the lower the time period the larger the jumps in numbers but the response to any change will be quicker. Remember, high damping for rough weather, low damping for calm weather.

Damping should not be confused with the update rate which is the number of times each second that the function value is sent to the display. This update rate is fixed for all functions.

## **1.7 MENU STRUCTURE**

The central concept to the operation of the system is the structure of the Function Menus accessed through the FFD; once these are understood operation becomes simple.

Regular users of computers will be familiar with the concept of structured menu layers. At each level there is a set of choices which can be scrolled through (selected) until the required menu is reached. When selected the FFD then displays the choice for the next menu level. The function options available through each menu choice are listed in Table 1.1 - Operating Functions. Operational Menu choices together with the Function Menu applicable are listed in Table 1.2 - Operational Menu Choices.

### **Note**

The Functions available to the user are dependent on the range of sensors fitted to the system. Details of the sensors required for each function are fully explained in Part 3 - Operating Information.

**Table 1.1 - Function Menu Choices**

<b>FUNCTION</b>	<b>MENU CHOICE</b>	<b>FUNCTION TEXT</b>
Speed	Boat Speed Average Speed	BOAT SPD AVG SPD
Log	Stored Log Trip Log	STD LOG TRIP LOG
Depth	Depth - Meters Depth - Feet Depth - Fathoms	DEPTH M DEPTH FT DEPTH FM
Navigate	Heading Off Course Dead Reckoning Course Dead Reckoning Distance Tidal Set Tidal Drift	HEADING OFF CRSE D/R CRSE D/R DIST TIDE SET TIDE RTE
Waypoint	Bearing Waypoint to Waypoint ?Mag. Bearing Waypoint to Waypoint ?True Bearing to Waypoint Rhumb ?Mag. Bearing to Waypoint Rhumb ?True Bearing to Waypoint Great Circle ?Mag. Bearing to Waypoint Great Circle ?True Distance to Waypoint Rhumb Distance to Waypoint Great Circle Course Over Ground ?Mag. Course Over Ground ?True Speed Over Ground VMG To Waypoint Time To Go to Waypoint Cross Track Error Latitude Longitude	BRG W-W ?M BRG W-W ?T BTW RMB ?M BTW RMB ?T BTW GC ?M BTW GC T DTW RMB DTW GC CRSE O/G ?M CRSE O/G ?T SPD O/G VMG WPT TTG WPT CROSS TR LATITUDE LONGTUDE
Temperature	Sea Temperature Degrees ?C Sea Temperature Degrees ?F	SEA TEMP ?C SEA TEMP ?F

**Table 1.2 - Operational Menu Choices**

<b>OPERATION</b>	<b>SELECTED FUNCTION(S)</b>	<b>OPERATIONAL CHOICE</b>
Log Control	Trip Log D/R Course D/R Distance	RESET RUN FREEZE
Alarm Control	BOAT SPD DEPTH SEA TEMP	ALL OFF HI ALARM HI ON HI OFF LO ALARM LO ON LO OFF
Sector Alarm Control	HEADING	ALL OFF SECTOR SECT ON SECT OFF
Damping Control	BOAT SPD HEADING TIDE	DAMPING VALUE
Calibrate Log (AUTO CAL)	BOAT SPD STD LOG	SINGLE CAL DIST STRT RUN STOP RUN END CAL
Calibrate Log (MANL CAL)	BOAT SPD STD LOG	SINGLE
Calibrate Log (REF CAL)	BOAT SPD STD LOG	REF CAL
Calibrate Datum	DEPTH	DATUM (+/-)
All Other Calibrate Functions	Selected Function	CAL VALUE 1 CAL VALUE 2 CAL VALUE 3 CAL VALUE 4

## PART 2 - OPERATING INFORMATION

### CONTENTS

<b>Para</b>		<b>Page</b>
2.1	FULL FUNCTION DISPLAY (FFD)	2-3
2.1.1	The Keys	2-3
2.1.2	On/Off Illumination Key	2-4
2.1.3	Page Key	2-4
2.1.4	Scroll Keys	2-4
2.1.5	Enter/Reset Key	2-5
2.1.6	Speed/Depth (SPD/DEP) Key	2-5
2.1.7	Navigation (NAV) Key	2-5
2.1.8	Temperature (TEMP) Key	2-6
2.1.9	Remote Push-Button Operation	2-6
2.2	20/20 DISPLAY	2-6
2.3	SUPER HALCYON 3 AND HALCYON 2000 COMPASS	2-6
2.4	EXAMPLES OF OPERATION	2-7
2.4.1	Function Selection	2-7
2.4.2	Page Display Configuration	2-8
2.4.3	NAV Key Configuration	2-8
2.4.4	Damping Adjustment - Boat Speed	2-9
2.5	EXAMPLES OF CALIBRATION	2-10
2.5.1	Calibration Adjustment - Boat Speed	2-10
2.5.2	Calibration Adjustment - Depth	2-10
2.6	ALARMS	2-11
2.6.1	Alarm Control	2-11
2.6.2	Alarm Types	2-11
2.6.3	Set Lo Alarm - Depth	2-12
2.6.4	Switch Alarms - On/Off	2-12
2.6.5	Disable Alarms	2-13
2.7	TRIP FUNCTIONS	2-13
2.7.1	Fast Reset	2-13
2.7.2	Reset Timer	2-13

## CONTENTS (Contd)

<b>Para</b>		<b>Page</b>
2.8	LIGHTING CONTROL	2-14
2.8.1	Select Local Control	2-14
2.8.2	Select System Control	2-14
2.9	OPERATING NOTES	2-15
2.10	OPERATING FUNCTIONS	2-15
2.10.1	Average Speed	2-15
2.10.2	Bearing to Waypoint	2-16
2.10.3	Bearing Waypoint to Waypoint	2-16
2.10.4	Boat Speed	2-16
2.10.5	Course Over Ground	2-17
2.10.6	Dead Reckoning	2-17
2.10.7	Depth	2-19
2.10.8	Distance to Waypoint	2-19
2.10.9	Heading	2-20
2.10.10	Local Time of Day	2-20
2.10.11	Next Waypoint Distance	2-20
2.10.12	Sea Temperature	2-21
2.10.13	Speed Over Ground	2-21
2.10.14	Stored Log	2-21
2.10.15	Tidal Set and Drift	2-22
2.10.16	Time to Waypoint	2-23
2.10.17	Trip Log	2-23

## ILLUSTRATIONS

<b>Fig No</b>		<b>Page</b>
2.1	Full Function Display	2-3
2.2	Sector Alarm	2-11
2.3	Dead Reckoning	2-18

## PART 2 - OPERATING INFORMATION

### 2.1 FULL FUNCTION DISPLAY (FFD)

The HS 2000 System is operated by using the keys on any one of the NMEA or Standard Full Function Displays (FFD).

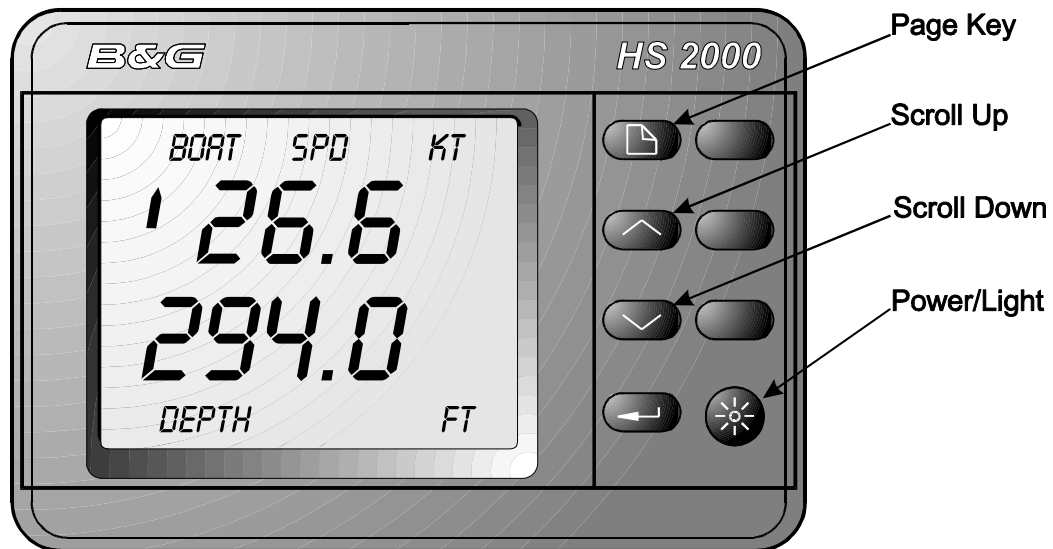

Fig 2.1 - Full Function Display

The information displayed on each FFD consists of a page of information comprising an upper display and a lower display. The user has four pages which may be configured to display any available function in either the upper or lower displays. Any function may be selected and displayed at any time in either the upper or lower display.

In addition to these there are three factory set displays for Speed/Depth, Temperature and Navigate functions. These displays are accessed by pressing the related key on the FFD.

#### 2.1.1 The Keys

The NMEA and Standard FFDs incorporate the following keys:

- On/Off Illumination
- Page
- Scroll Up
- Scroll Down
- Enter/Reset
- Speed/Depth
- Temperature
- Navigation

## 2.1.2 On/Off Illumination Key

This key controls the application of power to the system and the level of illumination at all displays.

One short press of this key applies power to the HS 2000 System and the display is activated. A second short press of the key provides full background illumination on all system displays. Further short presses of the key decrease the illumination in three stages from full brightness to OFF. The next press enables full illumination again. This operation at any FFD within the system, performs the same sequence on all HS 2000 displays connected to the system. Display lighting can be adjusted locally at each FFD. (See Paragraph 2.9 - Lighting Control).

To switch the system OFF, press and hold down the key for three seconds. After this time the message **POWER-OFF** appears in the upper display; release the key and after a further two seconds the system switches OFF.

## 2.1.3 Page Key

This key enables the user to select the User Defined Pages (Displays) presented on the FFD.

By pressing this key the user is able to choose any one of the four user defined page displays accessing various functions of the HS 2000 System (two functions per page).

### Notes

1. To return to the start position at any time press the **Page** Key.
2. Successive operations of the **Page** Key will display each of the user defined pages in rotation.
3. The initial four pages can be reconfigured to meet any specific needs using the remaining keys and the menu system as described in Paragraph 2.5.2.
4. To initiate control of 20/20 displays hold down the **Page** Key for 2 seconds (See Part 5 - Options).

## 2.1.4 Scroll Keys

Two scroll keys are provided: **Scroll Up** and **Scroll Down**. These keys have three functions:

- (a) To select the upper or lower display to change functions.
- (b) To scroll through (select) the menu choices.
- (c) To increase or decrease numerical values, such as calibration values or degrees.

After a specific page has been selected, pressing the **Scroll Up** Key selects the upper display. Similarly, operation of the **Scroll Down** Key selects the lower display.

### 2.1.5 Enter/Reset Key

The principle use of the **Enter** Key is to invoke selections chosen from the menu by the **Scroll** Keys. As a general rule, when any menu choice is flashing, pressing the **Enter** Key will select that choice. The **Enter** Key is also used to:

(a) **Enter Data.** When the data displayed requires changing press the **Enter** Key. The selected value flashes and by using the **Scroll Up** or **Scroll Down** Keys the data is changed. Press the **Enter** Key again to complete the operation.

(b) **Accept and Reset Alarms.** When an alarm sounds (if the audible warning is fitted) or flashes at the FFD, two presses of the **Enter** Key stops the warning and resets the alarm.

(c) **Expand Function Displays.** When displaying the Log and Timer functions the **Enter** Key can be used to expand the display. Normally the Log function displays distance to two decimal places, i.e. 99.99nm (maximum). One press of the **Enter** Key expands the display to 0099nm, giving a maximum available display of 9999nm, if required. Similarly the Timer function normally displays a minutes and seconds reading. Expansion by the **Enter** Key displays hours and minutes instead.

### 2.1.6 Speed/Depth (SPD/DEP) Key

By pressing the **SPD/DEP** Key the user is able to select any one of three factory set displays accessing the Speed and Depth functions. Successive operation of the **SPD/DEP** Key will display the following information in a fixed order:

Boat Speed/Depth  
Boat Speed/Speed Over Ground  
Boat Speed/Apparent Wind Angle

### 2.1.7 Navigation (NAV) Key

By pressing the **NAV** Key the user is able to select any one of three factory set displays accessing the Navigation functions. Successive presses of the **NAV** Key will display the following information in a fixed order:

Current Heading/Course Over Ground  
Current Heading/Boat Speed  
Distance to Waypoint/Bearing to Waypoint

## Note

The NAV key may be configured to show waypoint information in either Great Circle or Rhumb modes. Refer to section 2.4.3 for further details.

### 2.1.8 Temperature (TEMP) Key

By pressing the TEMP key the user is able to select any one of two factory set displays accessing the temperature functions. Successive presses of the TEMP key will display the following information:

Sea Temperature/Depth  
Air Temperature/Depth

### 2.1.9 Remote Push-Button Operation

Each FFD may be used with an optional Remote Push-Button. This allows basic control of the associated FFD from a remote position. The Remote Push-Button has two functions: page selection and fast reset.

Page selection is achieved by successive pressing of the Remote Push-Button. When pressed, each of the four user defined pages are displayed, followed by the first page of the factory set pages for Speed/Depth, Navigate and Temp.

When any one of the trip functions is selected at the associated FFD, pressing and holding down the Remote Push-Button for two seconds will change the display to show RESET flashing. Pressing the Remote Push-Button again will Reset that function. After a reset the display will revert to normal page set-up.

## 2.2 20/20 DISPLAY

The 20/20 is a fully programmable, single function display, incorporating a large digit display which can be installed at any location in the boat.

Control of the 20/20 Display may be achieved from any FFD or from an optional Remote Push-Button (see Part 5 - Options).

## 2.3 SUPER HALCYON 3 AND HALCYON 2000 COMPASS

The Super Halcyon 3 and Halcyon 2000 Compasses are high performance electronic transmitting compasses which interface with your HS 2000 System. Heading and direction information can be

selected for display on any of the FFDs or the Halcyon Display. In addition analogue compass card type displays may be added.

### **Note**

Analogue displays require an additional Wind Board (402-10-005) to be installed in the processor box.

Software incorporated with the compass allows the compass to learn the magnetic fields in the vessel which may cause deviation errors. These errors can be reduced to an insignificant level by following the Calibration procedure described in Part 3.

## **2.4 EXAMPLES OF OPERATION**

The general principle of operating the HS 2000 System will be made clear by the following examples of function and page selection, and damping.

### **2.4.1 Function Selection**

Our first example will be to select another function for one of the displays. The new function is Stored Log which we want to place in the lower display.

(1) Select the lower display by pressing the **Scroll Down** Key. The lower display will start to flash. The upper display is not affected.

(2) Using the **Scroll Up** and/or **Scroll Down** Keys, scroll through the menu until the required menu (LOG) is shown flashing in the lower display. The upper display is not affected.

(3) Press the **Enter** Key, the lower display now shows the STD LOG flashing, the upper display is not affected.

### **Note**

If another menu choice is required (for example, Trip Log), scroll through the menu choices using the **Scroll Up/Scroll Down** Keys until the required choice is displayed in the lower display.

(4) Press **Enter** again, the lower display now shows required function, the upper display is not affected.

At this stage we have simply called up this function for viewing, if the **Page** Key is pressed, then the configured page will return and Stored Log will no longer be displayed. If, however, you wish to keep Stored Log on a page, then you can configure the page.

## 2.4.2 Page Display Configuration

To store the setting in Paragraph 2.5.1 as a permanent new page, proceed as follows:

- (1) Press **Scroll Up** or **Scroll Down** and scroll text until CNFG DSP is shown on the display.

### Note

**Scroll Up** or **Scroll Down** can be used because we are configuring the whole page; both upper and lower displays.

- (2) Press **Enter**, PAGE is shown on the lower display.
- (3) Press **Enter**, the digital display is blanked and the two functions selected are displayed in the upper and lower displays.
- (4) Press **Enter** to accept the new page configuration and restore the digital display.

As you become increasingly familiar with the system you will be able to set up each FFD on the boat for the crew members in the vicinity. Each crew member will be able to develop their own pages for the information most often required.

All page displays are held permanently in the display memory, independent of the power supply.

## 2.4.3 NAV Key Configuration

Our second example is configuring the NAV key. The NAV key may be configured to display either Rhumb Line or Great Circle navigation information. To select the required mode, proceed as follows:

- (1) Press the **Page** Key once.
- (2) Press **Scroll Up** until the upper display shows CNFG DSP flashing.
- (3) Press **Enter**, the upper text now shows PAGE flashing.
- (4) Press **Scroll Up** to select either NAV MODE GC (Great Circle) or NAV MODE RH (Rhumb).
- (5) Press **Enter** to select your desired choice. The display will stop flashing.

## 2.4.4 Damping Adjustment - Boat Speed

Our second example is the entry of a damping value. To ascertain whether it is possible to damp a function, you should check the table in Paragraph 2.10 - Operating Functions.

- (1) Using the **Scroll Up** or **Scroll Down** Key select the upper or lower display as required.
- (2) If BOAT SPD is shown in the upper display, press and hold **Scroll Down** and scroll to DAMPING, which flashes. If BOAT SPD is shown in the lower display, use **Scroll Up**.
- (3) Press **Enter**, the current damping value will be displayed on the upper or lower display, as appropriate.
- (4) Press **Enter**, the DAMPING value will start to flash.
- (5) Press **Scroll Up** or **Scroll Down** to increase and/or decrease the damping value, as required.
- (6) Press **Enter** to accept new value.
- (7) Press **Page** to return to full display.

Damping control for any of the other functions that can be damped is achieved in a similar manner.

## 2.5 EXAMPLES OF CALIBRATION

The method of calibration of your HS 2000 System should be made clear by the following examples. The Calibration Process is described in detail in Part 3 - Calibration.

### 2.5.1 Calibration Adjustment - Boat Speed

- (1) Using the **Scroll Up** or **Scroll Down** Keys select the upper or lower display as required.
- (2) If BOAT SPD (or STD LOG) is shown in the upper display, press and hold the **Scroll Down** Key to select CALBRATE from the menu. If BOAT SPD (or STD LOG) is shown in the lower display use **Scroll Up**.
- (3) Press **Enter** and then press **Scroll Down** to select MANL CAL on the display.
- (4) Press **Enter**, SINGLE is shown on the Display.
- (5) Press **Enter** to view the current calibration value in Hz/knot.
- (6) To adjust the calibration value, press **Enter** and the value flashes.
- (7) Use the **Scroll Up** and **Scroll Down** Keys to change the calibration value to the new calibration value.
- (8) Press **Enter** to store the new calibration value into the system.
- (9) Press **Page** to return to the normal display.

### 2.5.2 Calibration Adjustment - Depth

- (1) Using the **Scroll Up** or **Scroll Down** Keys select the upper or lower display as required.
- (2) If DEPTH is shown in the upper display, press and hold the **Scroll Down** Key to select CALBRATE from the menu. If DEPTH is shown in the lower display, use **Scroll Up**.
- (3) Press **Enter**, the display shows DATUM, which flashes.
- (4) Press **Enter** again, DATUM stops flashing and the current datum value is displayed.
- (5) Press **Enter**, the DATUM value flashes.
- (6) Use **Scroll Up** or **Scroll Down** Keys to set the new DATUM value.

#### Note

If DATUM is referenced to the water line, the value is positive. If

DATUM is referenced to the keel line, the value is negative, which is indicated by a minus sign before the left hand digit.

(7) Press **Enter** to input the new DATUM value into the system.

(8) Press **Page** to return to the normal display.

## 2.6 ALARMS

### 2.6.1 Alarm Control

When a pre-set alarm parameter is reached, for example, the depth reducing, the system raises an alarm automatically. In an alarm condition, the lower display changes to highlight the cause of the alarm, which flashes red and green alternatively until the **Enter** Key is pressed twice. At which point all FFDs, with the exception of the FFD on which **Enter** was pressed, return to normal. The audible alarm, if fitted, is also silenced by this operation. After this, the lower display continues to monitor the alarm condition. The alarm is still active; if the alarm parameter is again exceeded the alarm will flash/sound as necessary. The displayed alarm function remains on the lower display until **Page** is pressed.

### 2.6.2 Alarm Types

The system incorporates the following types of alarm:

**HI ALARM** - This is generated if the value of a function exceeds a pre-set level.

**LO ALARM** - This is generated if the value of a function drops below a pre-set level.

**SECTOR ALARM** - This is generated when the value of a function leaves the safe sector as shown in Fig 2.2.

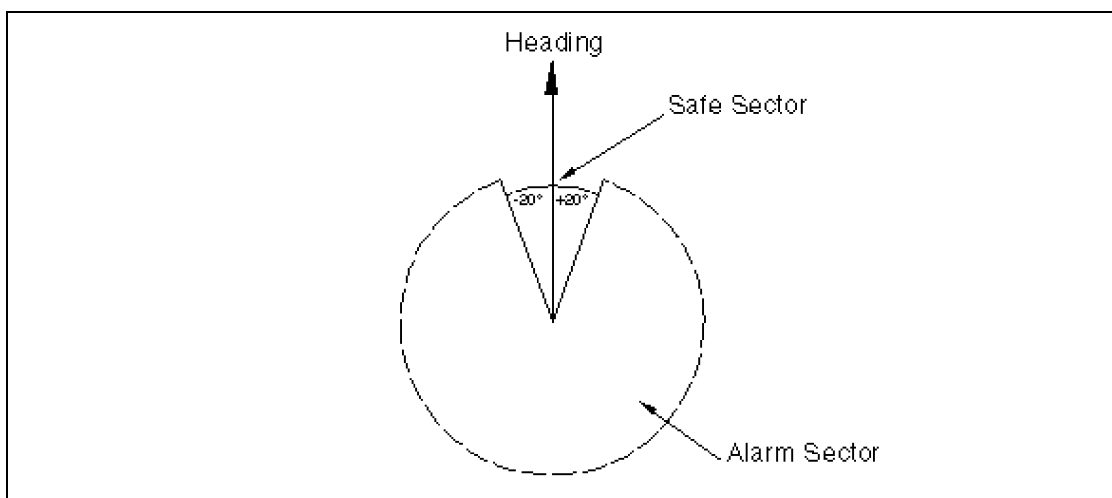

Fig 2.2 - Sector Alarm

For example, when the SECTOR alarm is turned on, the alarm reference heading is the current compass heading. If the SECTOR alarm is set at 40°, the sector value is the compass heading +/- 20°. It is therefore important to switch off the SECTOR alarm before carrying out a course alteration and switching the alarm on again when settled on the new course heading.

Any alarm can be turned ON and OFF individually, or all alarms can be turned OFF collectively.

### 2.6.3 Set Lo Alarm - Depth

(1) Select function which requires alarm facility, for example, DEPTH.

(2) If the selected function is in the upper display, press **Scroll Down** and scroll the lower display until ALARMS appears, flashing. If the selected function is in the lower display use **Scroll Up**.

(3) Press **Enter**, the text shows ALL OFF flashing.

(4) Use **Scroll Up** or **Scroll Down**, as appropriate, and scroll through until the text shows LO ALARM flashing.

(5) Press **Enter**, the display shows the current LO ALARM value.

(6) To change the LO value, press **Enter**, the value flashes.

(7) Press **Scroll Up** or **Scroll Down** to increase or decrease the value, as required. Press **Enter** to accept the new value and turn the alarm ON.

(8) Press **Page** to return to the normal display.

To access the HI alarm, scroll through the text until HI ALARM appears and press **Enter** to reveal current HI Alarm value. To change the value, use the same procedure as used to change the LO alarm value.

### 2.6.4 Switch Alarms - On/Off

To turn off an alarm (HI, LO or SECTOR), scroll through the menu until the required item (for example, HI OFF) appears in the upper display and press **Enter**.

To turn ON an alarm, scroll through until the required item (for example, LO ON) appears in the upper display and press **Enter**.

### 2.6.5 Disable Alarms

- (1) Select any function with an alarm facility, for example, DEPTH.
- (2) If function is in the upper display, press **Scroll Down** to scroll to ALARMS, or if function is on the lower display use the **Scroll Up** Key. Then press **Enter**, ALL OFF appears flashing.
- (3) Press **Enter** again, all alarms are turned OFF and the normal page display will be restored.

**WARNING - All alarms in the system will remain OFF until the values are reset or the individual alarms are turned on again.**

## 2.7 TRIP FUNCTIONS

The HS 2000 System provides two trip functions Trip Log and Dead Reckoning. The functions can be reset and restarted as required, for example, for keeping a separate log of elapsed distance for a given passage.

When any trip function is started, all other trip functions which have been reset start simultaneously.

When a trip function is displayed, the two right hand characters show the status of that function.

The letters MS (Minutes/Seconds) and NM (Nautical Miles) indicate the function is running.

The letters RE denote RESET, where the function is zeroed and waiting to be started.

The letters FR denote FROZEN, where the displayed value is frozen but the function is still counting in the background.

### 2.7.1 Fast Reset

The HS 2000 System incorporates a Fast Reset feature for all trip functions (Trip Log and Barometric Pressure Trend). Fast Reset can be initiated either by operation of a Remote Push-Button (see Paragraph 2.1.9) or by operation of the **Enter** Key on any FFD.

#### **Note**

If two trip functions are displayed simultaneously, the Fast Reset facility will only reset the function shown in the upper display.

### 2.7.2 Reset Trip Log

- (1) Display TRIP LOG in the upper display.

- (2) Press **Scroll Down** once and the lower text now shows CONTROL flashing.
- (3) Press **Enter** and use the **Scroll Down** key to display RESET flashing.
- (4) Press the **Enter** key and the display now shows RUN flashing.
- (5) Press the **Enter** key again and the display shows the trip log running.
- (6) Press the **Page** key to resume normal operation.

### Note

Each time you reset the TRIP LOG the AVERAGE SPEED resets and begins its calculation again. The control facility for the Dead Reckoned functions works in the same way; the bearing and distance are linked so that they start simultaneously.

## 2.8 LIGHTING CONTROL

The level of illumination at system displays is controlled by the **Power/Light** Key. Use of this key normally controls all the HS 2000 System displays simultaneously. However, the level of illumination on a single FFD can be controlled individually using the menu choice - LOCAL LIGHTING.

### 2.8.1 Select Local Control

- (1) Press and hold **Scroll Up** or **Scroll Down** until LIGHTING appears in the text.
- (2) Press **Enter**.
- (3) Press **Scroll Up** until LOCAL is displayed.
- (4) Press **Enter** again, the original page display appears. Control of the FFD is now in local mode.

Successive operation of the **On/Off Illumination** Key now controls the current display only. This will enable you to use very low lighting at the chart table while maintaining the brightness up on deck.

### 2.8.2 Select System Control

- (1) Press and hold **Scroll Up** or **Scroll Down** until LIGHTING is displayed in the text.
- (2) Press **Enter** and **Scroll Up** or **Scroll Down** to select SYSTEM.

(3) Press **Enter** again, the original page display appears and the illumination control has returned to System Control.

### Note

In order to control the lighting on analogue repeaters, at least one FFD must be set to System Control.

## 2.9 OPERATING NOTES

Within the foregoing paragraphs of this part of the Manual the steps necessary to select a specific function and/or set-up the system have been described in detail. The remainder of this Manual contains some detailed examples; therefore to describe further operations the following shorthand system has been adopted.

Each successive selected menu choice will be in capitals, separated by a ? symbol. For instance the example in Paragraph 2.5.1, to manually calibrate the log, would be presented as follows:

SPEED ? BOAT SPD, **CALBRATE ? MANL CAL ? SINGLE**

Menu choices in plain CAPITALS are the selection of the required function. Menu choices in **BOLD** are the selection of the relevant operation and are completed using the other half of the display.

## 2.10 OPERATING FUNCTIONS

The previous paragraphs have described how the HS 2000 System is constructed and how to use both the keys and basic menu structure. The following paragraphs describe each of the functions available in greater detail and how these features can best be applied within the boat.

### 2.10.1 Average Speed

Menu Heading: SPEED  
Function Text: AVG SPD  
Update Rate: Once per second  
Units: Knots

Average speed is a trip function that averages your speed through the water over the period the Trip Log has been running.

$$\text{Average Speed} = \frac{\text{Trip Log}}{\text{Time it has been running}}$$

### 2.10.2 Bearing to Waypoint

Menu Heading:	WAYPOINT
Function Text:	BTW RMB or BTW GC
Update Rate:	Provided by position fixer
Units:	Degrees magnetic, degrees true

#### Notes

1. Requires interfaced position fixing system.
2. Rhumb, Great Circle, Magnetic or True.

Once the position fixer is connected and sending information, it automatically appears in the menu and becomes available for display.

### 2.10.3 Bearing Waypoint to Waypoint

Menu Heading:	WAYPOINT
Function Text:	BRG W-W
Update Rate:	Provided by position fixer
Units:	Degrees magnetic, degrees true

#### Note

Requires interfaced position fixing system.

This is the bearing from a waypoint to the next waypoint in the position fixer's route.

### 2.10.4 Boat Speed

Menu Heading:	SPEED
Function Text:	BOAT SPD
Update Rate:	Four times per second
Units:	Knots

#### Notes

1. Variable damping 0-99 seconds.
2. Acceleration, deceleration indicator.
3. Audible, high/low alarm available.

Boat Speed is the most fundamental piece of information on the HS 2000 System. It is used in many of the calculations of higher functions.

The accurate calibration of the Paddle-Wheel or XTL Unit is essential. The HS 2000 System has a simple procedure for calibrating the underwater units which is described in Part 4 - Calibration.

Boat Speed is shown on the display with a small bar to the left of the digits which indicates the increase or decrease of speed. The amount of damping that is applied can be adjusted. This can be

increased to smooth out the display value in rough conditions or conversely, reduced to accelerate the response in light conditions.

### 2.10.5 Course Over Ground

Menu Heading: WAYPOINT  
Function Text: CRSE O/G  
Update Rate: Provided by position fixer  
Units: Degrees magnetic, true

#### Note

Requires interfaced position fixer.

Once the position fixer is connected and sending information it automatically appears in the menu and becomes available for display. This is your actual track over ground and invaluable to the navigator for helping him/her to deal with tidal areas.

### 2.10.6 Dead Reckoning

Menu Heading: NAVIGATE  
Function Text: D/R CRSE or D/R DIST  
Update Rate: Once per second  
Units: Degrees magnetic, nautical miles

#### Notes

1. Course and distance.
2. Corrected for leeway if heel sensor fitted.
3. Changeable as a trip function.

Formerly the mainstay of all offshore navigation, now with such widespread use of electronic position fixing equipment Dead Reckoning is more often used as an essential back up which can be particularly effective as an indicator of the net course steered. Both the course as a bearing from the start point, and its distance in nautical miles, can be displayed as separate functions.

In the worst case, Man Overboard, immediately resetting the DR will bring the boat back to the position of entry because DR is the measurement of course over the water and not over the land as given by a position fixer.

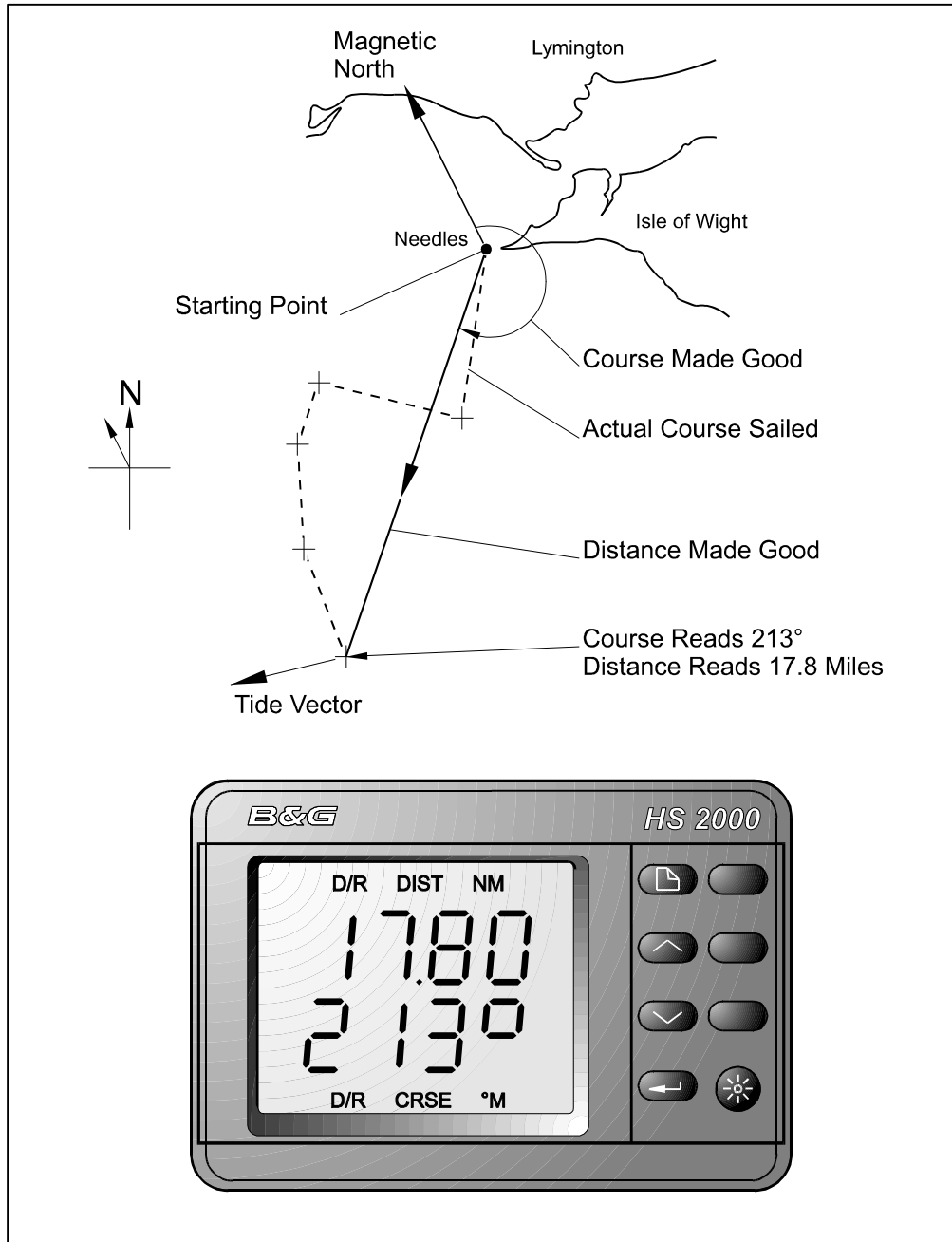

Fig. 2.3 - Dead Reckoning

### 2.10.7 Depth

Menu Heading: DEPTH  
Function Text: DEPTH  
Update Rate: Once per second  
Units: Metres, feet and fathoms

#### Note

Audible, shallow/deep alarm available:

Shallow range 0-99.9m  
Deep range unlimited

Depth is one of the most important functions on the boat, being an essential navigational and safety tool. A datum adjustment allows you to move the base point to give either depth under the keel or actual water depth (see Paragraph 2.5.2).

Depth sounder performance is dependent on many factors: transducer type and installation, boat speed, electrical noise, sea state, sea bed conditions, air and plankton in the water. However effective the equipment, there will always be times when a reliable measurement of depth is not possible. In these cases, such as following in the wake of another boat, the display shows the pattern below to indicate a signal problem.

-  
- -  
-

The accuracy of the measurement is dependent on the velocity of sound and the degree to which the sound penetrates the sea bottom. Changes in the velocity of sound are not normally significant, however, errors up to one foot can result from sound penetration into very soft mud.

### 2.10.8 Distance to Waypoint

Menu Heading: WAYPOINT  
Function Text: DTW RMB or DTW GC  
Update Rate: Provided by the position fixer  
Units: Nautical miles

#### Note

Rhumb or Great Circle.

Once the position fixer is connected and sending information, it automatically appears in the menu and becomes available for display.

### 2.10.9 Heading

Menu Heading: NAVIGATE  
Function Text: HEADING  
Update Rate: Twice per second  
Units: Degrees magnetic

#### Notes

1. Adjustable damping, 0-99 sec.
2. Sector alarm available.
3. Sensor alignment calibration.

This is the compass heading, derived directly from the electronic Fluxgate Compass; a basic input for the system that allows calculation of dead reckoning and other course related navigation functions.

The Halcyon 2000 Compass automatically corrects for deviation due to the magnetic fields of the boat.

### 2.10.10 Local Time of Day

Menu Heading: TIME  
Function Text: LOC TIME HR  
Update Rate: Provided by position fixer  
Units: Hours, minutes, seconds

#### Notes

1. Requires NMEA 0183 interfaced position fixing system. transmitting the ZLZ sentence.
2. Check that the Local Time Offset is entered on the position fixer correctly.

This function normally shows the Local Time of Day in hours and minutes as given by the position fixer. To view minutes and seconds press the **Enter** Key once. A further press of the **Enter** Key returns the display to hours and minutes.

### 2.10.11 Next Waypoint Distance

Menu Heading: WAYPOINT  
Function Text: NEXT WPT NM  
Update Rate: Provided by position fixer  
Units: Nautical miles

#### Note

Requires NMEA 0183 interfaced position fixing system. WDC sentence. This is the distance in nautical miles from the current selected waypoint on your position fixer to the next waypoint on route.

### 2.10.12 Sea Temperature

Menu Heading: TEMP  
Function Text: SEA TEMP  
Update Rate: Once per second  
Units: Degrees Centigrade, Fahrenheit

#### 1. Notes

- Requires temperature sensor.
- Audible high/low alarm available.

Knowledge of sea temperature is useful on long voyages when ocean currents are determined by changes in water temperature. Temperature can also be useful when in the vicinity of river outlets. The changes in temperature between fresh and sea water can provide knowledge of favourable currents.

### 2.10.13 Speed Over Ground

Menu Heading: WAYPOINT  
Function Text: SPD O/G  
Update Rate: Provided by position fixer  
Units: Knots

#### Note

Speed Over Ground input is available from the position fixing system. Comparing the speed over ground to the speed through the water is useful in strong tidal waters. It is also useful at night when the only indication of tide change is the comparison of speed over the ground and speed through the water.

### 2.10.14 Stored Log

Menu Heading: LOG  
Function Text: STD LOG  
Update Rate: Once per second  
Units: Nautical miles

The stored log runs continually, and is always available as an accumulative total of the mileage run. The stored log is not changeable; the Trip Log is used for this purpose.

Normally the Log function displays nautical miles to two decimal places, i.e. 99.99nm (maximum). One press of the **Enter** Key expands the display to 0099nm giving a maximum available display of 9999nm if required.

## 2.10.15 Tidal Set and Drift

Menu Heading:	NAVIGATE
Function Text:	TIDE SET or TIDE RTE
Update Rate:	Once per second
Units:	Degrees magnetic, knots

### Notes

1. Damping 0-99 minutes.
2. Calibration: Magnetic variation.
3. Some position fixers output the current local magnetic variation on the NMEA 0183 port using either HVD, HVM, RMA or RMC sentences. As a result CAL VAL 1 on the TIDE SET function will automatically set to the correct variation.

Your position fixer will either supply a true or magnetic bearing to the HS 2000 System. If it supplies true bearing then you must enter the magnetic variation into the HS 2000 System. It is found in the menu under:

NAVIGATE ? TIDE SET, **CALBRATE ? CAL VAL 1 (MAG VAR)**

### Note

If the position fixer sends magnetic bearing, check that the variation is correctly entered into the position fixer.

The calculation involves comparing the course and speed over the ground from the position fixer to the course and speed of the boat through the water, from dead reckoning. Any differences are due to the tidal set and drift and can be displayed as such. The damping on this function is adjustable and this can be important; in rapidly changing tidal situations you need to lower the damping down to be able to see changes quickly; conversely, in a steady tide or current, the longer the time over which the calculation is averaged, the more accurate the results will be. The lag in the position fixer's ability to adjust to rapid changes in direction should also be taken into account when considering the results of this function.

### 2.10.16 Time to Waypoint

Menu Heading: WAYPOINT  
Function Text: ETA WPT  
Update Rate: Provided by position fixer  
Units: Hours, minutes

#### Notes

1. Also gives ETA.
2. Requires interfaced position fixing system.

This is calculated directly by the position fixer and is based on your speed over the ground towards the mark which it assumes will be constant.

### 2.10.17 Trip Log

Menu Heading: LOG  
Function Text: TRIP LOG  
Update Rate: Once per second  
Units: Nautical miles

#### Note

Individually changeable.

This is the reset log for trip recording, and reads from the moment started, in nautical miles. It must be remembered that this is the distance travelled through the water, not over the ground. It also forms part of the calculation for Average Speed. A useful feature is that if the Trip Log is reset prior to the start of a trip, when the Timer counts down to zero the Trip Log (and any other trip functions that have been reset) start automatically.

The Trip Log display can be expanded to 9999 nautical miles by pressing the **Enter** Key.

## PART 3 - CALIBRATION

### CONTENTS

<b>Para</b>		<b>Page</b>
3.1	INTRODUCTION	3-3
3.2	BOAT SPEED/LOG CALIBRATION	3-3
3.2.1	Principle of Log Calibration	3-3
3.2.2	Preparation for Log Calibration	3-3
3.2.3	Calibration Runs	3-4
3.2.4	Log AUTO CAL Facility	3-4
3.2.5	Log AUTO CAL Procedure	3-5
3.2.6	Manual Calibration	3-6
3.2.7	Speed Calibration Referenced to a Known Value	3-6
3.2.8	Boat Speed Calibration	3-6
3.3	COMPASS CALIBRATION	3-7
3.3.1	Principles of Compass Calibration (Super Halcyon 3 & Halcyon 2000 Compasses)	3-7
3.3.2	Compass Heading Node Selection	3-8
3.3.3	Super Halcyon 3 Compass Calibration Procedure	3-9
3.3.4	Halcyon 2000 Compass Calibration Procedure	3-10
3.4	DEPTH CALIBRATION	3-12
3.5	SEA TEMPERATURE CALIBRATION	3-12
3.5.1	Sea Temperature Offset Calibration	3-13

### ILLUSTRATIONS

<b>Fig No</b>		<b>Page</b>
3.1	Log Calibration Runs	3-4
3.2	Depth Datum	3-12

**Intentionally Left Blank**

## PART 3 - CALIBRATION

### 3.1 INTRODUCTION

**WARNING - Every care must be taken when undertaking any calibration procedure to ensure that the HS 2000 System is calibrated accurately and correctly. Incorrect calibration could lead to incorrect navigational information.**

Calibration of an integrated instrument system is one of the most misunderstood processes. Good instruments badly calibrated will achieve very little. This part of the manual provides simple instructions, which, when carefully undertaken in the correct order, will consistently produce satisfactory results.

There are four basic inputs to your system that are fundamental to the integrated approach: boat speed, compass heading, depth and sea temperature.

These four basic inputs must be correctly calibrated before the values of greater interest can be derived. On any boat the calibration of these items should be high on the list of task priorities following the launch. Finally, it is crucial to keep a full record of the process.

### 3.2 BOAT SPEED/LOG CALIBRATION

#### 3.2.1 Principle of Log Calibration

To calibrate the log it is necessary to ascertain the number of revolutions of a paddle-wheel, or sonic blips per second, that correspond to each knot of boat speed. The boat speed/log calibration value is always shown as Hertz/knot (Hz/kt).

#### 3.2.2 Preparation for Log Calibration

Before calibrating the log you should ensure that the speed sensor unit is correctly aligned as follows:

**Paddle-Wheel** - The moulded arrows on top of the unit must be pointing forward along the fore and aft line of the hull. The unit must also be completely free of any weed or other fouling.

**Sonic Speed** - Check that the unit is operating correctly as per the owner's manual.

### 3.2.3 Calibration Runs

Consecutive runs at a constant speed should be made over a known distance. To eliminate the effect of tidal conditions, it is advisable to perform at least two runs, preferably three, along the measured track. There are three available options for calibrating the log; Automatically (AUTO CAL), Manually (MANL CAL) or Reference (REF CAL).

### 3.2.4 Log AUTO CAL Facility

This facility enables the user to calibrate the boat's log accurately and simply as all calculations are performed internally by the HS 2000 computer. Referring to Fig 3.1, A and B are the two markers for each run and X is the actual distance for each run as ascertained from the chart.

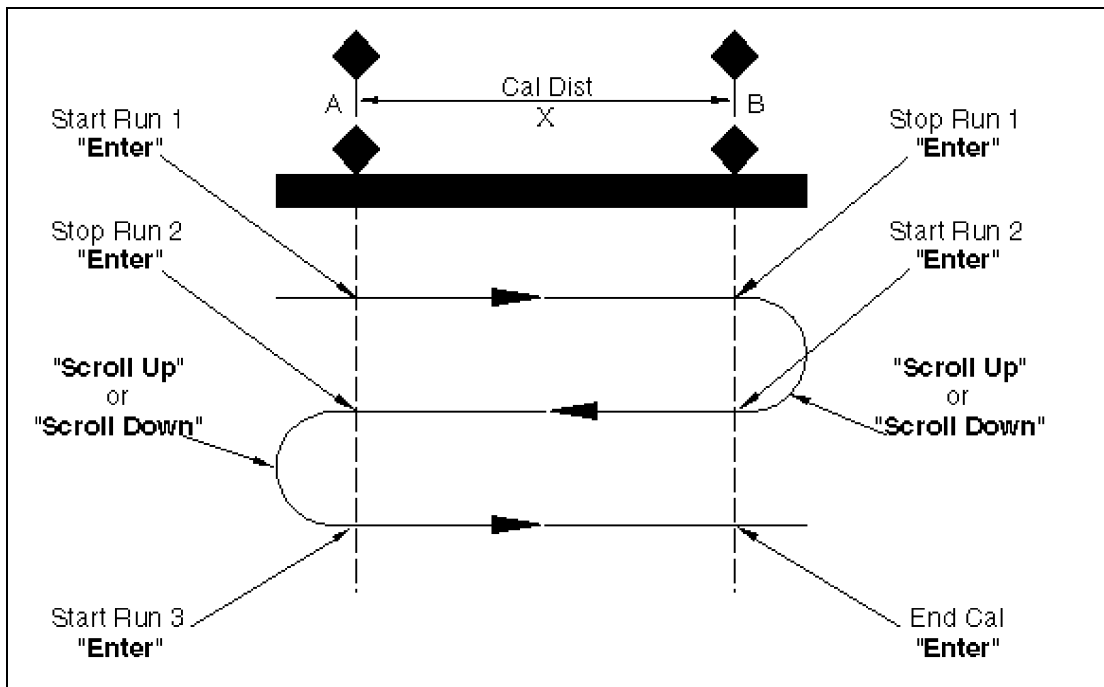

Fig 3.1 - Log Calibration Runs

The user is required to enter the distance X in nautical miles (CAL DIST) and then, as the boat passes marks A and B on each run, to instruct the system to start (STRT RUN) and stop (STOP RUN) and finally to end calibration (END CAL) after the last required run is complete.

#### Note

The calibration process can be canceled at any time during the operation by pressing the **Page** Key if the operator is not satisfied with the calibration runs, for example, when hampered by another vessel or wash.

### 3.2.5 Log AUTO CAL Procedure

- (1) Select BOAT SPD on the display.
- (2) If BOAT SPD is in the upper display, press and hold **Scroll Down** to select CALBRATE. If BOAT SPD is in lower display, use **Scroll Up** to select CALBRATE.
- (3) Press **Enter**, the display shows the current boat speed reading with AUTO CAL flashing.
- (4) Press **Enter**, the display shows the current boat speed reading with SINGLE flashing.
- (5) Press **Enter** twice, the display shows the default setting for the actual calibration distance for each run along the given course.
- (6) Press **Enter**, the CAL DIST will flash. The **Scroll Up** and **Scroll Down** Keys can now be used to select the appropriate measured distance. Press **Enter** to accept the new distance. The system is now ready to start the first calibration run.
- (7) Press **Scroll Down**, STRT RUN appears flashing.
- (8) When crossing the first transit mark of the run, press **Enter**, the display now shows the current boat speed reading with STOP RUN flashing.
- (9) When crossing the transit mark at the end of the run press **Enter**, the display shows the current boat speed reading with END CAL flashing.
- (10) Press **Scroll Down** to select STRT RUN again, then repeat steps (8) and (9).
- (11) If only two runs are required, press **Enter** to end calibration. The lower display will now show the new calibration value which has automatically been calculated by the computer unit. This should be recorded on the chart provided.
- (12) If a third run is required, press **Scroll Down** to select STRT RUN, then repeat from step (8).

The boat's log is now calibrated and the new calibration value is stored permanently in the computer unit's memory.

#### Note

"Err" will be displayed if the system encountered a problem during the calibration run. For example, if the cal' distance was too short.

### 3.2.6 Manual Calibration

The calibration values can be adjusted directly as shown in 'Examples of Calibration' included in Part 2 - Operating Information.

### 3.2.7 Speed Calibration Referenced to a Known Value

The following enhancement is only available when HS 2000 speed/depth computer is used in conjunction with an HS 2000 FFD Display with a software version later than 5C.

To calibrate the boat speed with reference to a known value, for instance, another boat with an accurately calibrated log, proceed as follows:

Select BOAT SPD KT on the upper half of the FFD display.

- (1) Press **Scroll Down** until the lower text shows CALBRATE flashing.
- (2) Press **Enter**, the lower text now shows AUTO CAL flashing.
- (3) Press **Scroll Down** until the lower text shows REF CAL flashing.
- (4) Press **Enter**, the lower text now shows REF CAL together with the current boat speed.
- (5) Press **Enter**, the lower text now shows REF CAL flashing and by use of the **Scroll Up/Down** the reference speed may be adjusted.
- (6) Press **Enter**, the new speed value is accepted and the upper display will show the re-calibrated boat speed.

### 3.2.8 Boat Speed Calibration (Knots, MPH, KPH)

To select the required boat speed units proceed as follows:

- (1) Press **Scroll Up** until the upper text shows LOG flashing.
- (2) Press **Enter**, the upper text now shows STD LOG flashing.
- (3) Press **Scroll Up** until the upper text shows TRIP LOG flashing.
- (4) Press **Enter** until the upper text shows TRIP LOG and the current value.
- (5) Press **Scroll Down**, until the lower text shows CALBRATE flashing.

(6) Press **Enter**, the lower text now shows CAL VAL 1 flashing.

(7) Press **Scroll Down** repeatedly, and the lower text will cycle through CAL1 VAL 1, CAL VAL 2, and CAL VAL 3

When CAL VAL 1 is displayed:

(8) Press **Enter**, the lower text shows SPD KTS.

When CAL VAL 2 is displayed:

(9) Press **Enter**, the lower text shows SPD MPH.

When CAL VAL 3 is displayed:

(10) Press **Enter**, the lower text shows SPD KPH.

For whichever selection is made:

(11) Press **Enter**, the lower text now shows SPD KTS, SPD MPH, or SPD KPH with the current boat speed value in the original units.

(12) Press **Enter**, the current boat speed value, in the original units, will flash.

(13) Press **Enter**, the current boat speed will be converted to and displayed in the newly selected units.

### **3.3 COMPASS CALIBRATION**

#### **3.3.1 Principles of Compass Calibration (Super Halcyon 3 & Halcyon 2000 Compasses)**

B&G's Autoswing Compasses contain software that allows them to record the magnetic fields in the yacht that are causing the deviation errors. It calculates the corrections every time the boat completes a 540° turn - Super Halcyon 3 or 360° turn - Halcyon 2000, provided the following conditions are met:

(a) The 540° turn - Super Halcyon 3 or 360° turn - Halcyon 2000 is completed in the same direction.

(b) The rate of change of heading does not exceed 3°/s; i.e. the turn should take about 3 minutes to complete.

(c) The rate of change of heading must not fall below 0.2 of a degree per second during the 540° turn - Super Halcyon 3, i.e. the 540° turn must not take longer than 45 minutes.

- (d) The rate of change in heading is constant.
- (e) Automatic calibration has been utilised by connecting the brown wire from the compass at the junction box (Super Halcyon 3 only).
- (f) The compass is installed in a location free from magnetic interference such as iron keels, engines, loudspeakers etc. Consideration should also be given to electrical cables which may carry excessive currents (e.g. navigation lights).
- (g) The compass is installed in a location as close to the centre line of the boat as possible. Avoid areas such as the fore peak and the sides of the hull where the effects of pitch and roll are at their greatest.
- (h) On steel hulled vessels, the compass will need to be installed above decks away from the effects of the hull. Ideally, the compass should be installed 4-5m (12-16ft) above deck level.

### 3.3.2 Compass Heading Node Selection

The HS 2000 System can accept heading data from a variety of different sources. These sources are known as Address Nodes and allow the system to identify which heading devices are connected to the system. The list below shows the various sources of heading available with its respective address node:

<b>Device</b>	<b>Node</b>
Super Halcyon 3 Compass	5
Halcyon 2000 Compass	16
PLC Type Pilot	17
ACP Type Pilot	18
NMEA Heading (NMEA FFD)	96

Select the required heading node by following the procedure below:

- (1) Press the **Scroll Up** key until NAVIGATE is shown in the text, flashing.
- (2) Press **Enter**, HEADING ?M will be shown flashing.

- (3) Press the **Scroll Up** key again until the display shows D/R CRSE ?M flashing.
- (4) Press **Enter**. D/R CRSE ?M will now stop flashing.
- (5) Press **Scroll Down** until the display shows CALBRATE.
- (6) Press **Enter** 3 times. The display now shows HDG NODE and will display a value which flashes.
- (7) Use the **Scroll Up** and **Scroll Down** keys to change the value to the required setting.
- (8) Press **Enter**.
- (9) Switch the system off, and then back on again to complete the calibration process.

### Notes

1. Hydra Pilots, Hercules Pilots, HS Pilots and Halcyon FFDs will also require the Heading Node to be set to your desired choice. Refer to the relevant user manual for further information.
2. displays will require Heading to be re-selected. Simply re-select this function and refer to section 5.3.5 for more information.

### 3.3.3 Super Halcyon 3 Compass Calibration Procedure

- (1) Check for any magnetic devices placed near the compass, especially ones that are out of their normal places.
- (2) On a calm day select a stretch of open water with little traffic, (so you will not have to take avoiding action that would ruin the calibration). The flatter the water and the less the wind the easier it will be to meet the conditions for the calibration.
- (3) Check for any large steel structures nearby that may cause additional erratic deviations.
- (4) At a speed of about three knots slowly motor the boat through a full one and a half turns (540°), taking six to fifteen minutes to complete the one and a half turns. At this rate the heading should be changing at no faster than one degree every second. Having a watch beside the

compass display should considerably assist the helmsman in monitoring the rate of turn. The rate of turn is indicated on the Halcyon Display.

(5) When the compass has completed its calibration, the displayed heading will rotate in the opposite direction for 360° and settle on the correct bearing to indicate the calibration is complete. You should continue to turn until you see this.

### Note

If the displayed heading does not reverse, the calibration was discarded because the conditions were not met. You must start again, or try another day when wind and wave conditions are calmer.

(6) Eliminate any constant error in heading. These are normally checked for by using shore-based transits, once the error is known it can be eliminated by entering the value into the HS 2000 under:

NAVIGATE ? HEADING, **CALBRATE ? CAL VAL1**

For example, the compass was reading 320 degrees and it should read 316, then the value to enter would be -4.

### 3.3.4 Halcyon 2000 Calibration Procedure

(1) Check for any magnetic devices placed near the compass, especially ones that are out of their normal places.

(2) On a calm day select a stretch of open water with little traffic (so you will not have to take avoiding action which would ruin the calibration). The flatter the water and the less the wind the easier it will be to meet the conditions for calibration.

(3) Check for any large steel structures nearby, that may cause additional, erratic deviations.

(4) Scroll to the NAVIGATE menu and select COMP CAL on the top half of the display. The display shows OFF.

(5) Press **Scroll Down** until the lower text shows CALBRATE flashing.

(6) Press the **Enter** key twice to display START and a default setting of '0'.

- (7) Press the **Enter** key once and the '0' starts to flash. Use the **Scroll Up** key to change the value to '1'.
- (8) Press the **Enter** key. The display now shows 000?.
- (9) At a speed not exceeding five knots, turn the boat through 360° at a rate not greater than 2-3° per second. The display will show the amount of turn completed so far. Continue to turn the boat until the display shows PASS or FAIL.

### Notes

1. The compass calibration swing may be aborted at any time. To do this, press the **Enter** key once. Next, using the **Scroll Down** key change the value from '1' to '0', and then press **Enter** to store. The display will now show OFF.
2. The first time the system is switched on, or after a system reset, the Heading will alternate with CAL. This is to indicate to the user that the compass must be calibrated. This will disappear after the compass has been calibrated.

(10) Eliminate any constant error in heading. These are normally checked for by using shore-based transits, once the error is known it can be eliminated by entering the value into the HS 2000 under:

NAVIGATE ? HEADING, **CALBRATE ? CAL VAL1**

For example, the compass was reading 320 degrees and it should read 316, then the value to enter would be -4.

### 3.4 DEPTH CALIBRATION

A typical transducer installation is through the hull at a suitable position between the water line and the bottom of the keel. A DATUM (offset value) can be set, such that the depth display refers to either the water line or the keel line.

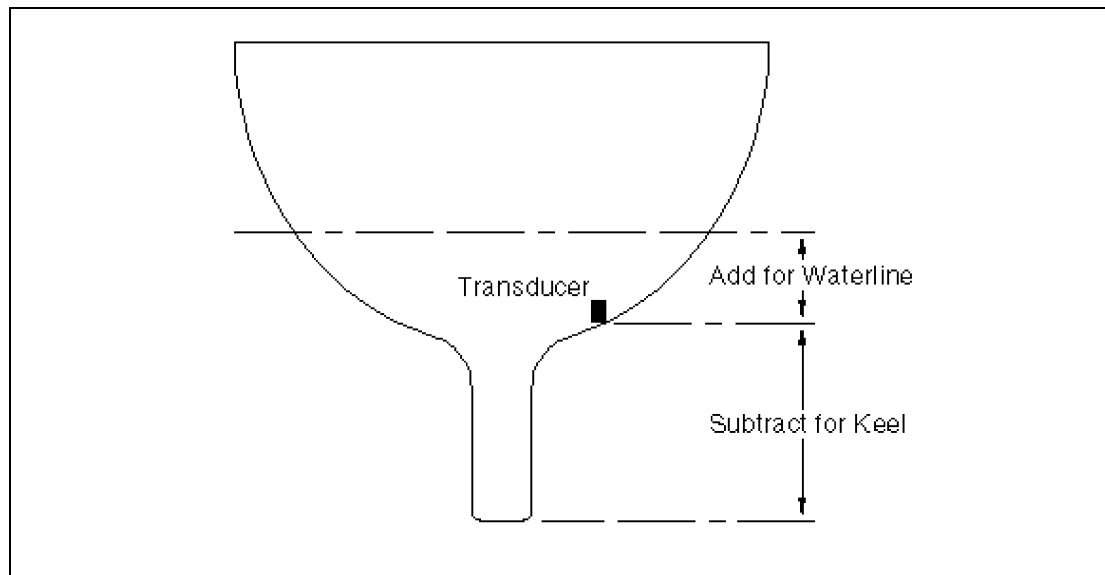

Fig 3.2 - Depth Datum

The datum is entered under:

DEPTH ? DEPTH, **CALBRATE ? DATUM**

### 3.5 SEA TEMPERATURE CALIBRATION

If a suitable temperature sensor is fitted, the HS 2000 System will monitor the current sea temperature; the paddle-wheel has a sensor incorporated within, in this case no further action is required.

If the sensor is a totally independent fitting (B & G Part No. 223-00-027) then it is necessary to change the sensor selection value. This value is found in:

TEMP ? SEA TEMP, **CALBRATE ? CAL VAL1 (SENSORS)**

The default selection value is 1; this value should be set to 2.

### 3.5.1 Sea Temperature Offset Calibration

To calibrate SEA TEMP C or SEA TEMP F proceed as follows:

- (1) Select SEA TEMP C on upper half on FFD display.
- (2) Press **Scroll Down** until the lower text shows CALIBRATE flashing.
- (3) Press **Enter**, the lower text now shows CAL VAL 1 flashing.
- (4) Press **Scroll Down**, the lower text now shows CAL VAL 2 flashing.
- (5) Press **Enter**, the lower text now shows OFFSET C.
- (6) Press **Enter**, the lower text now shows OFFSET C flashing and by use of **Scroll Up/Down** the temperature should be changed to the reference value.
- (7) Press **Enter**, the offset value is accepted and the upper display will show the adjusted measured temperature.

Similarly the above calibration can be carried out if SEA TEMP F is initially selected.

The offset value is automatically converted so that both degrees C and F are adjusted correctly.

## PART 4 - INSTALLATION INFORMATION

### CONTENTS

<b>Para</b>		<b>Page</b>
4.1	INTRODUCTION	4-3
4.2	INSTALLATION DATA SHEETS	4-4

**Intentionally Left Blank**

## PART 4 - INSTALLATION INFORMATION

### 4.1 INTRODUCTION

This part of the manual contains information relating to the interconnection of the units that make up the HS 2000 system. It is provided to enable qualified technicians to fault find or undertake the installation of additional units and thereby increase the number of functions available.

The information provided consists of drawing sheets showing equipment options and the interconnections between them. Included on the installation data sheets are details of cables, cable colours, instructions for installation and Notes to assist the technician.

The installation sheets following are:

1. Alarm Unit, Network and Power Supply
2. Network Terminator
3. Super Halcyon 3 Compass
4. Twin XTL Fins Gravity Switch
5. Change Over Switch
6. Depth Transducer and Paddle/Sea Temperature Sensor
7. Triducer Installation Sheet
8. HS 2000 System Example
9. NMEA Full Function Display
10. Non-NMEA Full Function Display
11. Halcyon 2000 Compass

#### **Note**

All screens should be clamped and connected under the metal clamp bar located on the processor box.

## 4.2 INSTALLATION DATA SHEETS

### ALARM UNIT, NETWORK AND POWER SUPPLY INSTALLATION SHEET

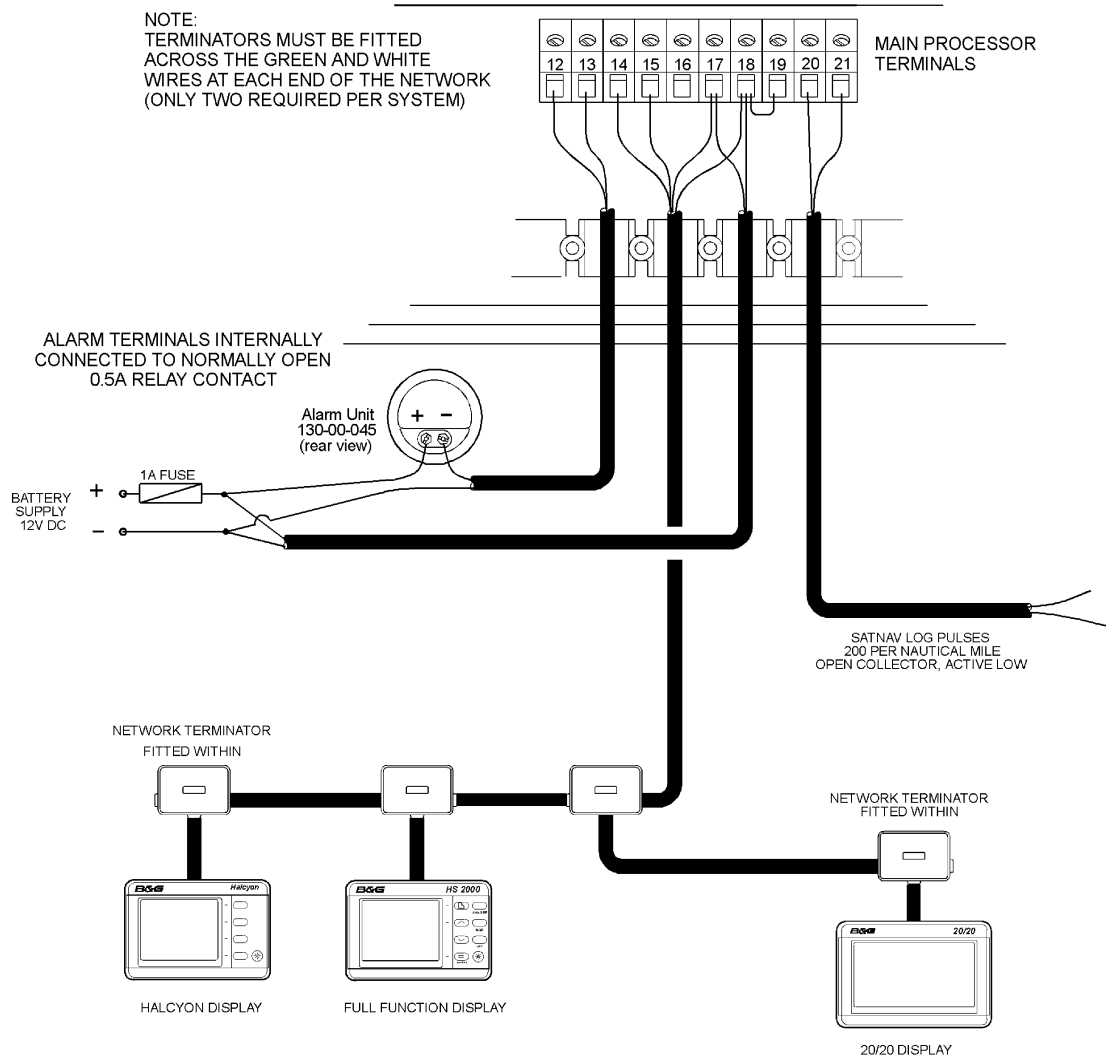

TERMINAL	FUNCTION	CABLE & WIRE COLOUR
12	ALARM UNIT	3m CABLE 135-0A-096
	ALARM	BLUE
13	ALARM	BROWN
14	SYSTEM NETWORK	10m CABLE 135-0A-130
	NETWORK DATA -	GREEN
	NETWORK DATA +	WHITE
	SUPPLY GROUND	BLACK
17	12V DC SUPPLY	RED
17	POWER SUPPLY	3m CABLE 135-0A-096
	GROUND	BLUE
	+12V DC SUPPLY	BROWN
19	BATTERY SENSE	LINK
20	SATNAV PULSES	3m CABLE 135-0A-096
	SATNAV PULSE OUTPUT	BROWN
21	GROUND	BLUE

NETWORK TERMINATOR INSTALLATION

THE NETWORK TERMINATOR 239-10-056 IS A BLACK TWO WIRED COMPONENT WITH A RESISTANCE OF 100 OHMS. TWO ARE SUPPLIED WITH INSULATING SLEEVING TO PREVENT SHORTING OF THE WIRES.

**IMPORTANT NOTE**  
A NETWORK TERMINATOR MUST BE FITTED ACROSS THE GREEN AND WHITE NETWORK DATA WIRES OF THE LAST UNIT OR JUNCTION BOX AT EACH END OF THE NETWORK CABLE. (SEE EXAMPLES BELOW)

WHEN ADDING MORE DISPLAYS OR UNITS TO THE NETWORK, ENSURE THAT THE TERMINATOR IS MOVED TO THE ENDS OF THE NETWORK CABLE. NEVER FIT MORE THAN TWO TERMINATORS ON THE NETWORK.

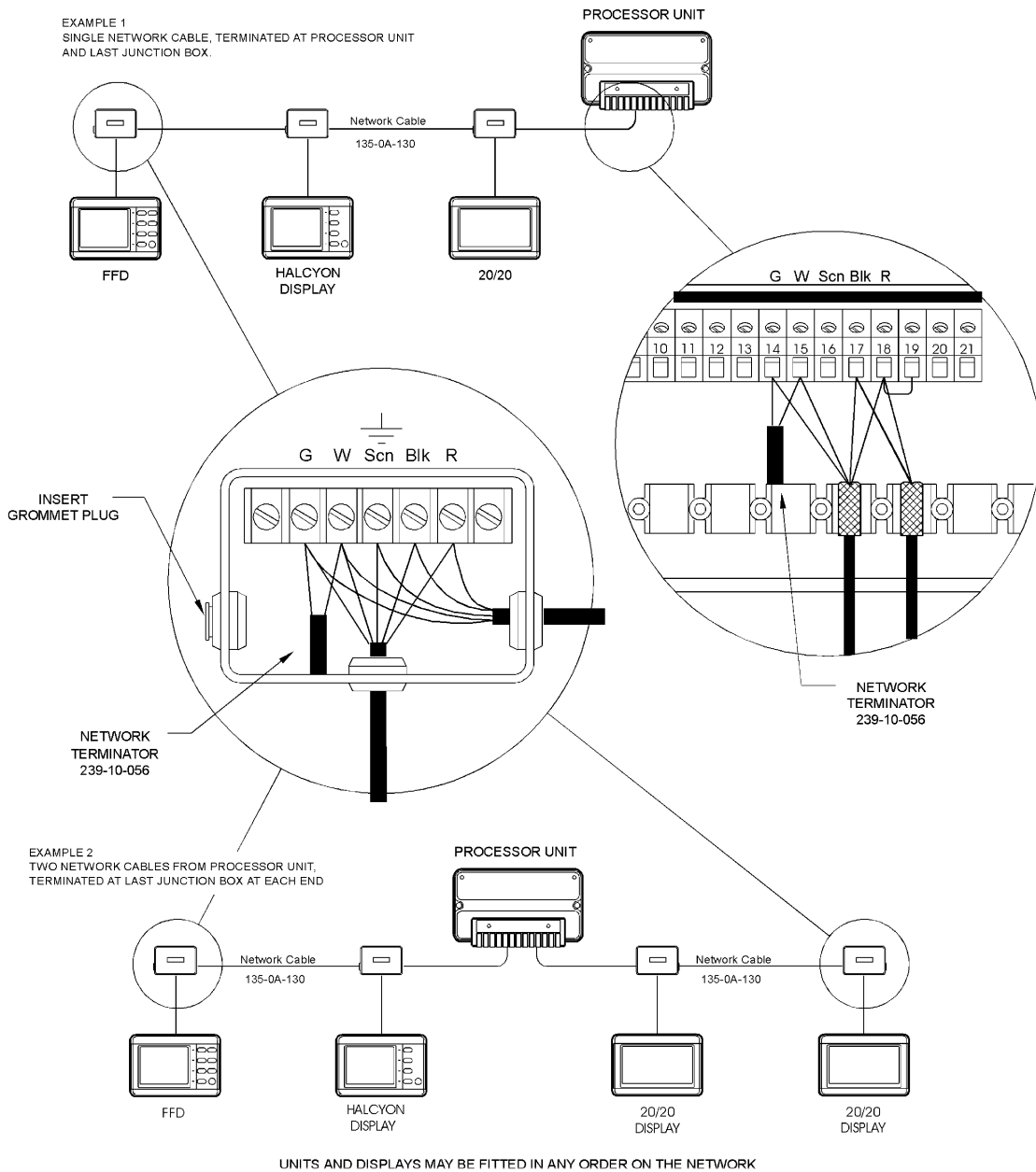

SUPER HALCYON 3  
 ELECTRICAL INSTALLATION SHEET

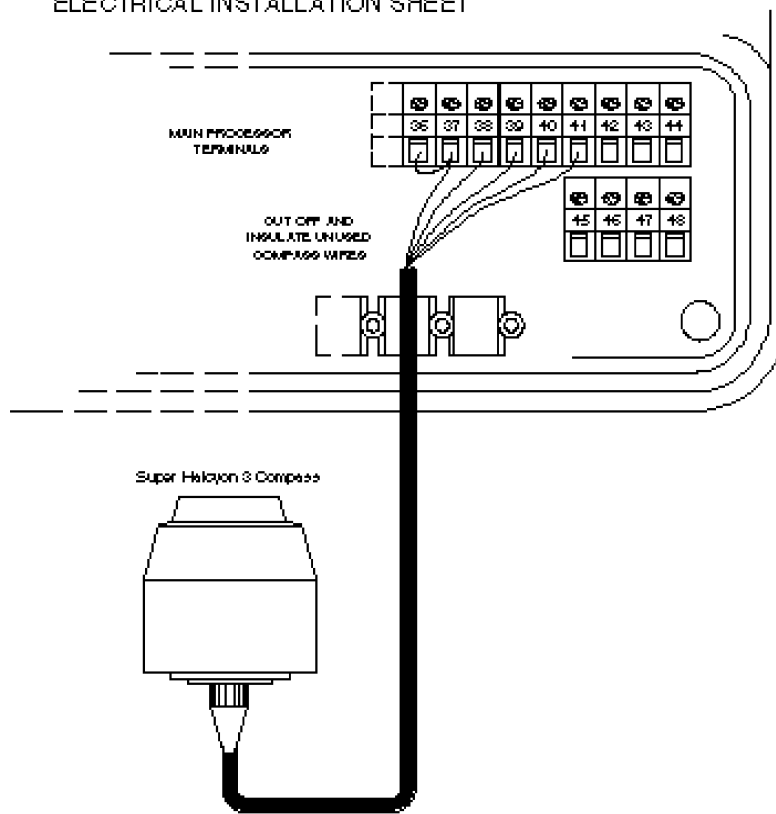

TERMINAL	FUNCTION	WIRE COLOUR
	COMPASS UNIT	15m CABLE 135-CA-113
36	REFERENCE OUTPUT	GREY ] LINK
37	REFERENCE INPUT	
38	GROUND	BLACK
39	COSINE	YELLOW
40	SINE	PINK
41	COMPASS SUPPLY (+12V)	ORANGE

- The Compass Unit is shown connected for the automatic compass swing facility. To connect for manually initiated compass swing refer to Owner's Manual 335-HB-0321
- For vessels with steel hulls the Compass Unit MUST be mounted outside of the magnetic screening effect of the hull and deck structure.
- Route the cable away from high current cables and components eg. starter motors and cables, alternators, trim tab cables etc.

TWIN XTL FINS GRAVITY SWITCH INSTALLATION

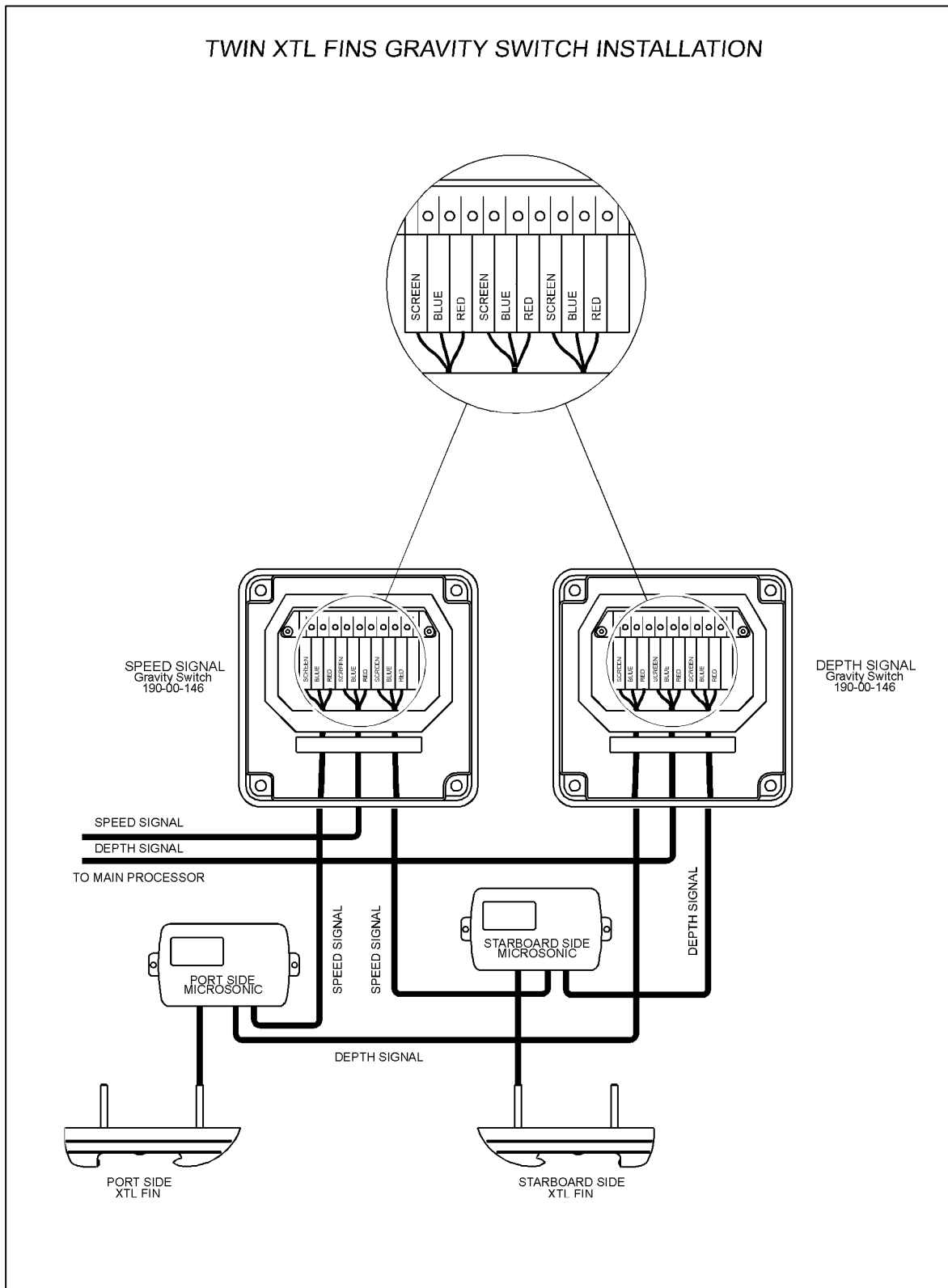

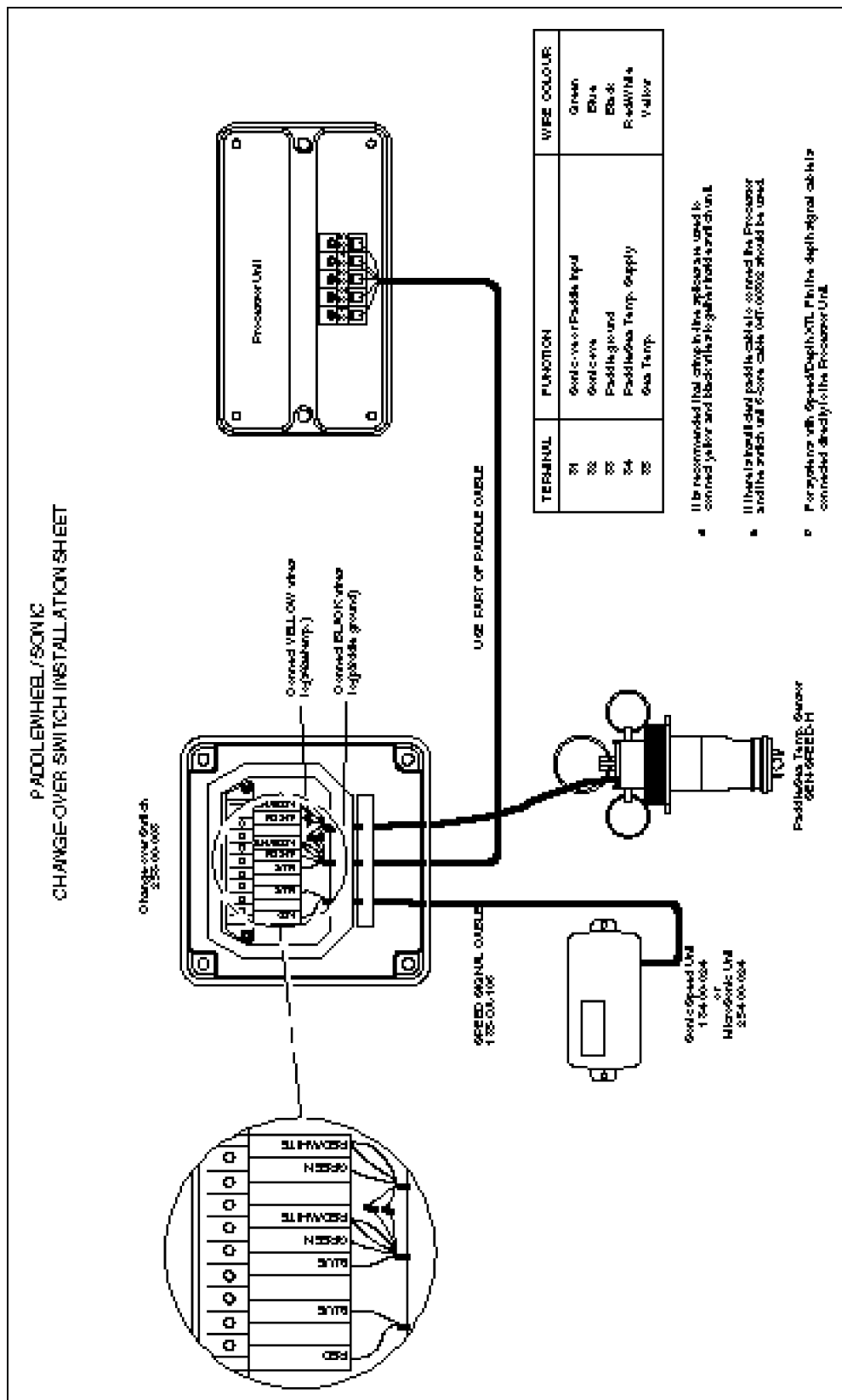

DEPTH AND PADDLE  
ELECTRICAL INSTALLATION SHEET

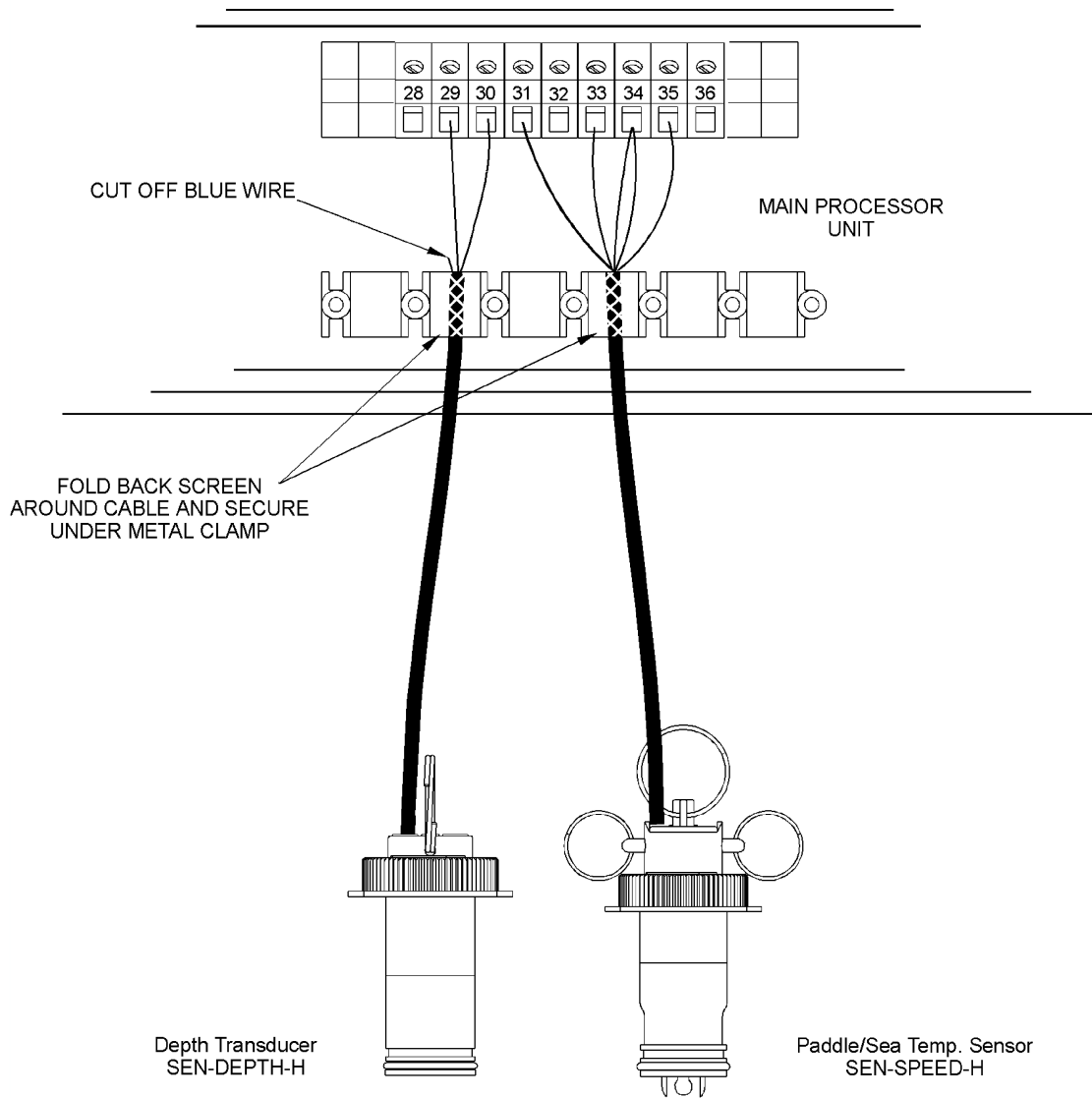

TERMINAL	FUNCTION	CABLE WIRE COLOUR
	DEPTH TRANSDUCER	16m CABLE ATTACHED
29 30	DEPTH - DEPTH +	BLACK BLUE
	PADDLE/SEA TEMP. SENSOR	16m CABLE ATTACHED
31	PADDLE INPUT	GREEN
32	NO CONNECTION	
33	GROUND	BLACK
34	SEA TEMP./PADDLE SUPPLY	RED AND WHITE
35	SEA TEMP. INPUT	YELLOW

### THROUGH HULL TRIDUCER INSTALLATION SHEET

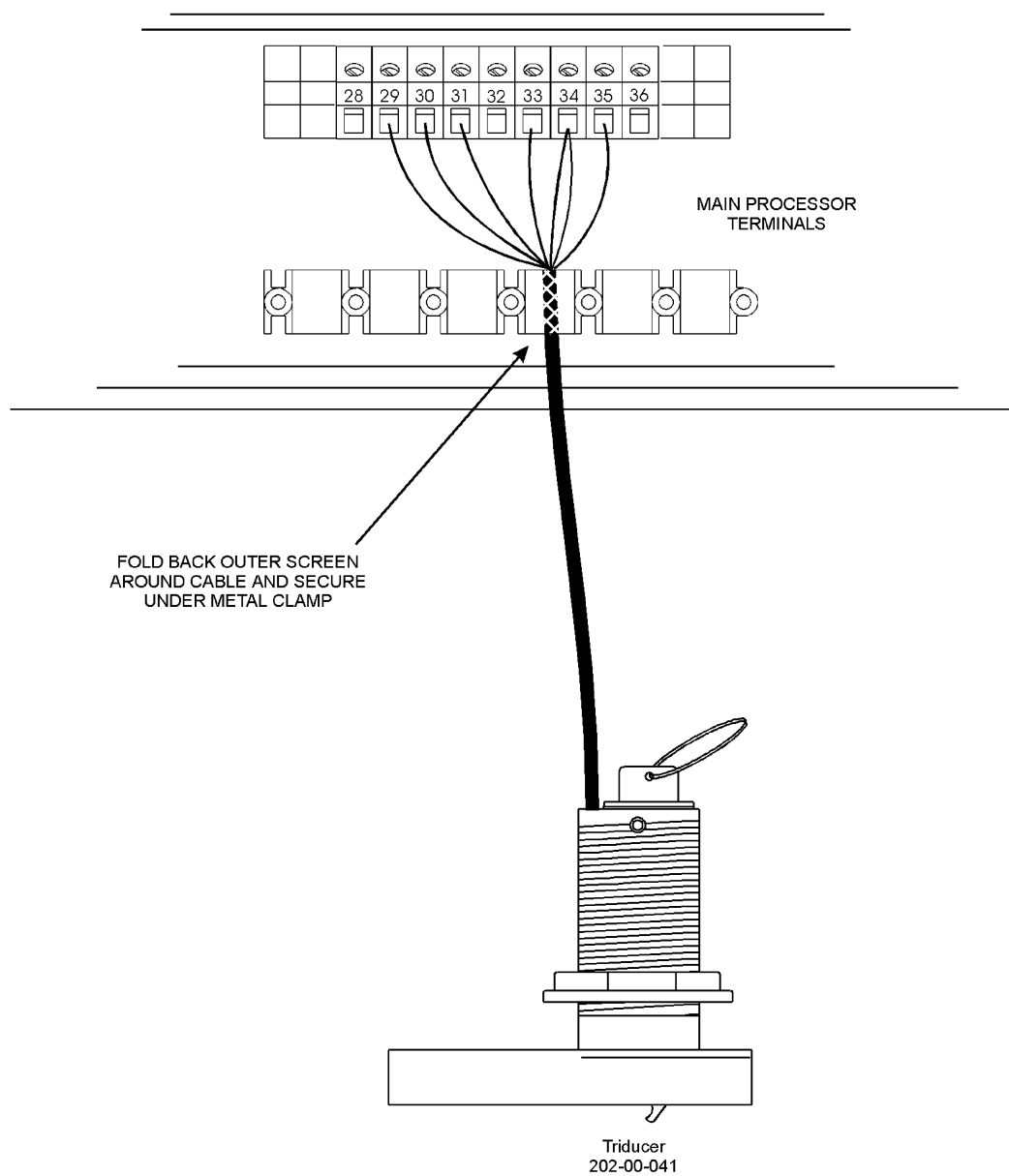

TERMINAL	FUNCTION	CABLE & WIRE COLOUR
	TRIDUCER DEPTH WIRING	INNER CORES
29	DEPTH -	BLACK
30	DEPTH +	BLUE
	TRIDUCER SPEED/TEMP WIRING	OUTER CORES
31	PADDLE INPUT	GREEN
32	NO CONNECTION	
33	GROUND	OUTER SHIELD
34	SEA TEMP./PADDLE SUPPLY	RED AND WHITE
35	SEA TEMP. INPUT	BROWN

HS 2000 SYSTEM EXAMPLE  
INSTALLATION REFERENCE SHEET

ITEM	UNIT	B&G PART NO.
1	MAIN PROCESSOR UNIT	330-00-005
2	ALARM UNIT	130-00-045
3	NMEA FFD Bezel	240-00-028 240-00-074
4	JUNCTION BOX	288-00-001
5	NETWORK TERMINATOR	239-10-056
6	DEPTH TRANSDUCER	SEN-DEPTH-H
7	SPEED SENSOR	SEN-SPEED-H
8	HALCYON 2000 COMPASS	486-00-009

OPTIONAL UNITS (NOT SHOWN)	B&G PART NO.
STANDARD FFD BEZEL	240-00-028 240-00-074
20/20 DISPLAY BEZEL	332-00-004 332-00-005
REMOTE CONTROLLER	302-00-007
MICROSONIC PACK	275-PK-10
GRAVITY CHANGEOVER SWITCH	190-00-146
GPSplus SYSTEM	NET-GPDU-SY

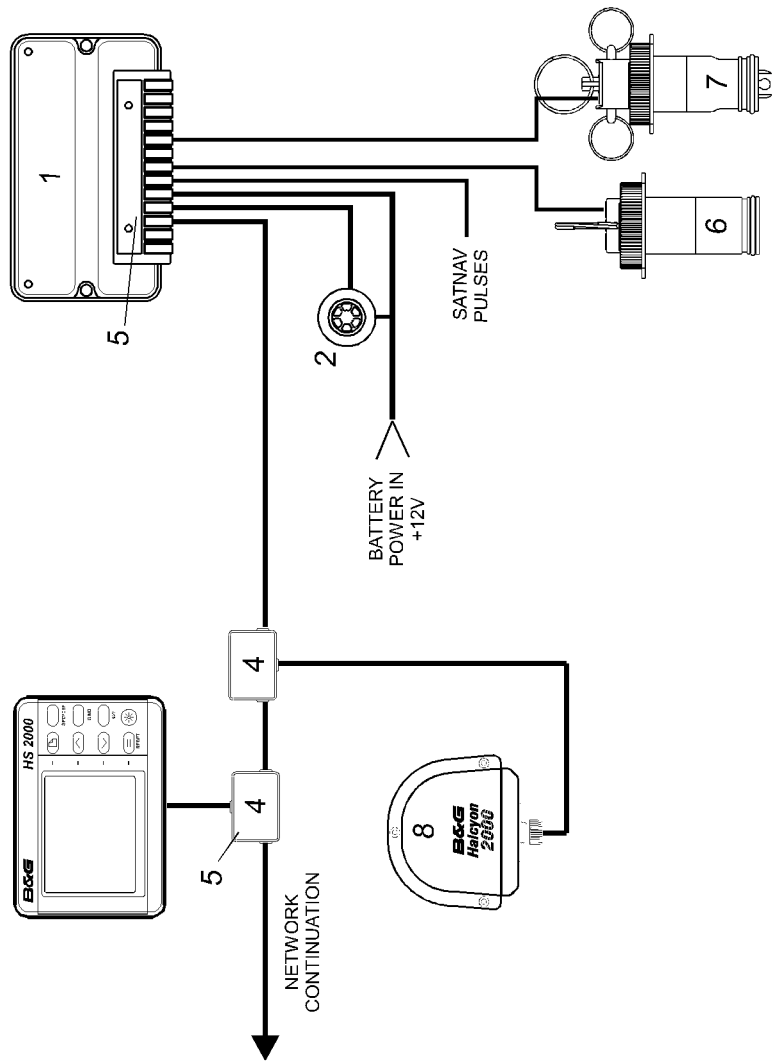

### 8-BUTTON NMEA FULL FUNCTION DISPLAY INSTALLATION SHEET

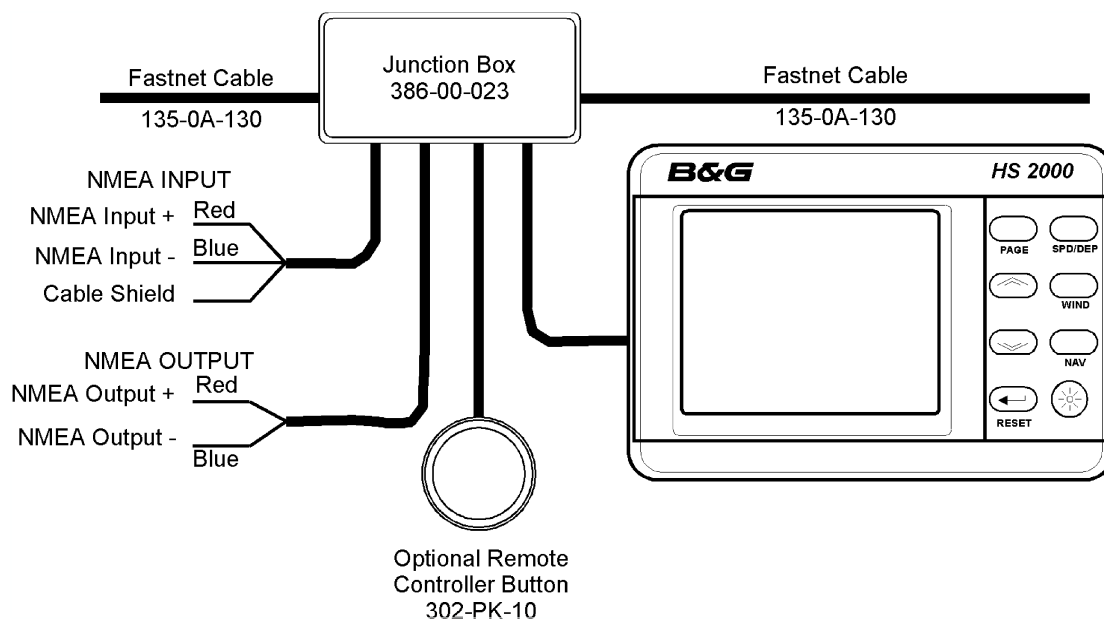

NMEA FFD CABLE FUNCTION	FFD CABLE COLOUR	SYSTEM NETWORK	NMEA INPUT	NMEA OUTPUT	REMOTE BUTTON
Network Data -ve	Green	Green	-	-	-
Network Data +ve	White	White	-	-	-
Network Cable Shield	Shield	Shield	-	Shield	-
Ground	Black	Black	-	Blue	Blue
Supply +ve	Red	Red	-	-	-
NMEA Input Signal	Brown	-	Red	-	-
NMEA Input Return	Blue	-	Blue	-	-
NMEA Output Signal	Violet	-	-	Red	-
Remote Control Button	Yellow	-	-	-	Red

#### INSTALLATION NOTES

- ?? An NMEA FFD can be connected at any point on the system network. Typically an NMEA FFD is mounted close to the NMEA device, e.g. at the chart table next to the GPS, thus minimising the NMEA cable routes.
- ?? NMEA FFD's can be used in combination with all other display types; i.e. standard FFD's, Halcyon displays, 20/20 and Pilot displays.

#### SCREENED CABLES

- ?? Shielded NMEA cables are supplied to provide protection against unwanted emissions (EMC) and must be connected in accordance with these instructions.
- ?? NMEA cable shields must be connected at the TRANSMITTING end.
- ?? The NMEA output cable shield should be connected to the other cable shields in the junction box supplied.

#### NETWORK TERMINATION

- ?? If the NMEA FFD is the last unit on the system network a network terminator MUST be fitted across the network data wires; i.e. between the green and white wires. Only two network terminators are required per system.

8 BUTTON FULL FUNCTION  
DISPLAY WIRING DETAILS

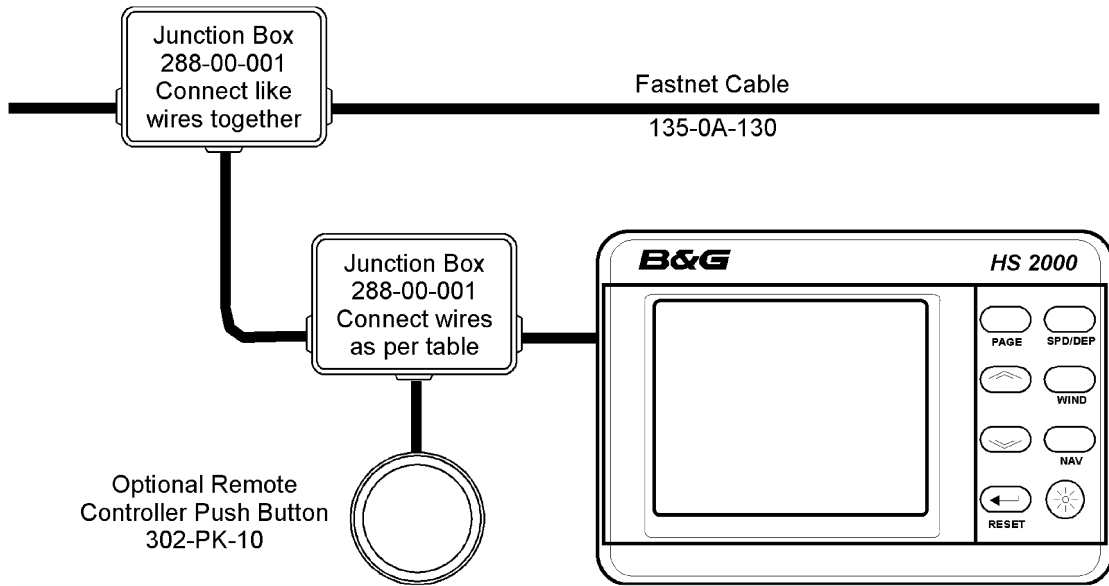

FFD CABLE FUNCTION	FFD CABLE COLOUR	SYSTEM NETWORK	REMOTE BUTTON
Network Data -ve	Green	Green	-
Network Data +ve	White	White	-
Network Cable Shield	Shield	Shield	-
Ground	Black	Black	Blue
Supply +ve	Red	Red	-
Remote Control Button	Yellow	-	Red
Not used	Brown	-	-

**INSTALLATION NOTES FOR HS 2000**

- ?? The system requires at least one FFD.
- ?? An FFD can be connected at any point on the system network.
- ?? Multiple FFD's can be used on the system network. Each can control and enter data into the system processor memory.
- ?? FFD's can be used in combination with all other display types; i.e. NMEA FFD's, Halcyon displays, 20/20 and Pilot displays.

**SCREENED CABLES**

- ?? Shielded cables are supplied to provide protection against unwanted emissions (EMC) and must be connected in accordance with these instructions.

**NETWORK TERMINATION**

- ?? If the FFD is the last unit on the system network a network terminator **MUST** be fitted across the network data wires, i.e. between the green and white wires.

# Halcyon 2000 Connection Diagram

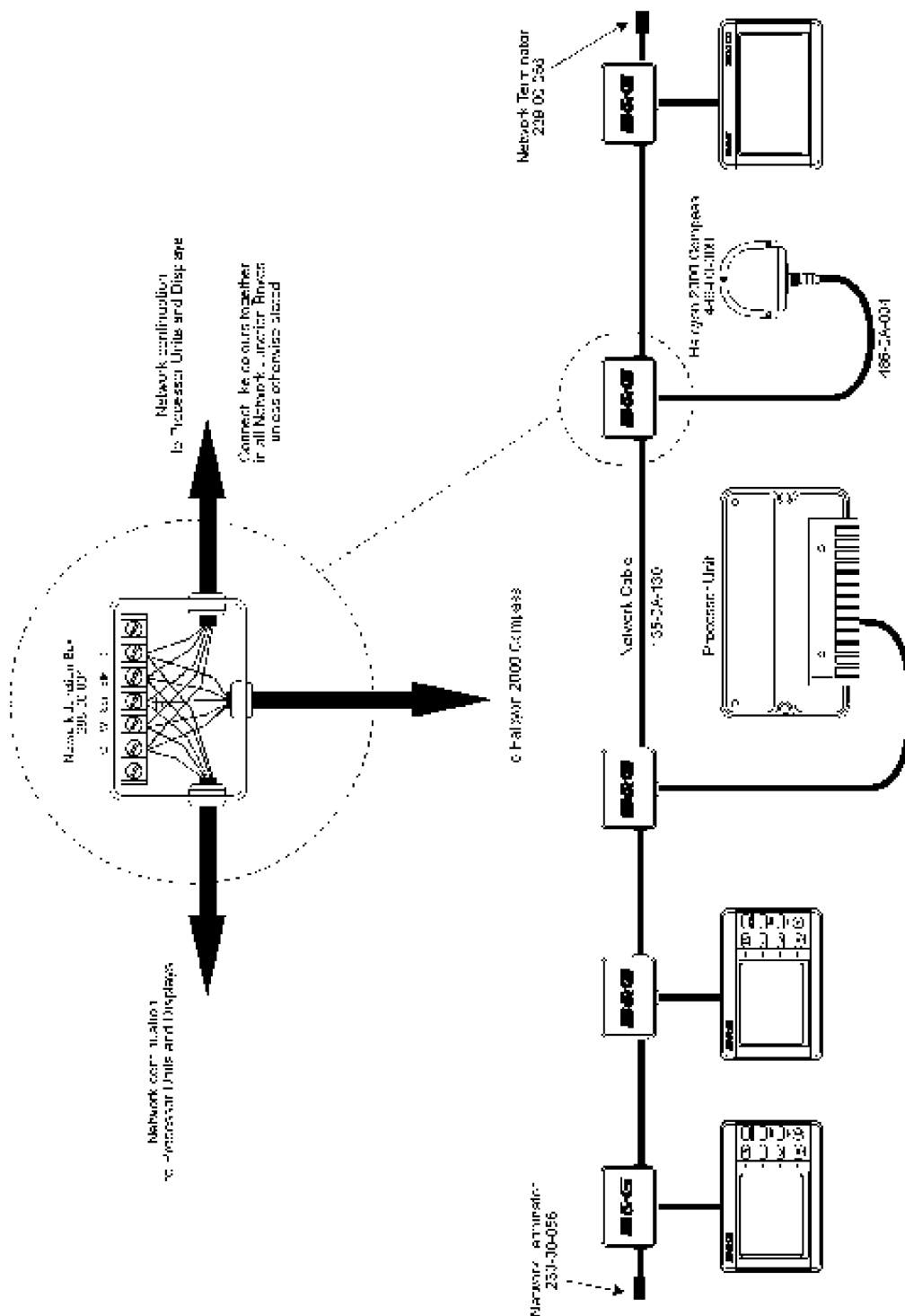

## PART 5 - OPTIONS

### CONTENTS

<b>Para</b>		<b>Page</b>
5.1	SYSTEM EXPANSION	5-3
5.2	AUDIBLE ALARM	5-3
5.3	20/20 DISPLAY	5-3
5.3.1	The Display	5-3
5.3.2	Display Configuration	5-4
5.3.3	Function Selection - Remote Push-Button	5-4
5.3.4	Function Selection FFD	5-4
5.3.5	Re-configuring 20/20 Display	5-5
5.4	HALCYON DISPLAY	5-6
5.4.1	The Keys	5-7
5.4.2	Power/Lights Key	5-7
5.4.3	Page Key	5-7
5.4.4	Operating Mode Selection	5-7
5.4.5	Off Course Function	5-8
5.4.6	Stored Course Function	5-8
5.4.7	Turn Rate Function	5-9
5.4.8	Mean Rate	5-9
5.4.9	Instantaneous Rate	5-10
5.5	HALCYON 2000 COMPASS	5-10

### ILLUSTRATIONS

<b>Fig No</b>		<b>Page</b>
5.1	20/20 Display	5-3
5.2	Halcyon Display	5-6

**Intentionally Left Blank**

## PART 5 - OPTIONS

### 5.1 SYSTEM EXPANSION

The HS 2000 System can be expanded to provide a wider range of facilities and features by the addition of further displays, sensors, and interfaces. These options are described in the following paragraphs.

### 5.2 AUDIBLE ALARM

The Main Processor contains a relay switch for an external audible alarm.

### 5.3 20/20 DISPLAY

#### 5.3.1 The Display

The 20/20 is a fully programmable, single function display, incorporating large digits, which may be installed virtually anywhere in the boat.



Fig 5.1 - 20/20 Display

### 5.3.2 Display Configuration

The 20/20 can be configured to display any function available on your HS 2000 System. It is, however, provided with 14 pre-set functions which may be selected by use of a Remote Push-Button connected to the display or via any FFD on the system.

The pre-set functions are as follows:

Boat Speed	Depth (m)
Depth (ft)	Compass Heading
Apparent wind Angle	True Wind Speed
True Wind Angle	Velocity Made Good
Compass Heading	Timer Count Up/Down
Bearing to Waypoint*	Course Over Ground*
Speed Over Ground*	True Wind Direction

#### Note

Functions marked with an asterisk are NMEA Functions and will not be available unless a position fixer is interfaced with the system.

### 5.3.3 Function Selection - Remote Push-Button

If a Remote Push-Button is connected to a 20/20 Display, any one of the 14 pre-set functions may be selected by pressing and holding down the associated push-button. The Display will then cycle through the functions. When the required function is displayed, release the Push-Button.

If the Push-Button is held down too long and the required function is missed, press and hold down the Push-Button again. The Display will then cycle through the functions in reverse order. When the required function is displayed, release the Push-Button.

### 5.3.4 Function Selection - FFD

An alternative to using a dedicated Remote Push-Button, is to control the 20/20 using any one of the standard FFDs in the system. If there are two or more 20/20s these can also be controlled from the same FFD.

To change the function displayed on a 20/20 using a standard FFD, proceed as follows:

- (1) At the FFD, press and hold down the **Page** Key for at least 3 seconds. The FFD display will change to show the function displayed on the 20/20 together with the display number. The selected Display will commence to flash.

- (2) Using the **Scroll Down** Key cycle through the 20/20 numbers and select the required Display Number.
- (3) Using the **Scroll Up** Key cycle through the 14 pre-set functions until the required function is displayed on the FFD. Release the **Scroll Up** Key.
- (4) If the function is missed, press and hold down the **Scroll Up** Key and the functions will cycle through in reverse order. Release the **Scroll Up** Key when the required function is displayed.
- (5) Press the **Page** Key. The FFD will now return to normal operation and the 20/20 display the selected function.

### 5.3.5 Re-configuring 20/20 Display

In addition to the 14 pre-set functions, any one of the 20/20 Displays may be re-configured to show any other function available to the system. This feature allows any 20/20 to be set-up to show the information most useful to the user at that station in the vessel.

The procedure for re-configuring a 20/20 function is as follows:

- (1) At the FFD, press and hold down the **Page** Key for at least 3 seconds. The FFD will change to show the function displayed on the 20/20 together with the display number.
- (2) Using the **Scroll Down** Key, cycle through the 20/20 numbers and select the one required
- (3) Using the **Scroll Up** Key select the function you wish to change.
- (4) Press the **Enter** Key and the function currently being displayed on the 20/20 will start to flash.
- (5) Press and hold down the **Scroll Up** Key and cycle through the normal FFD menu until the required function choice is displayed (e.g. NAVIGATE).
- (6) Press and hold down the **Scroll Down** Key until the required operational choice is displayed (e.g. COURSE).
- (7) Press the **Enter** Key to accept the selection.
- (8) Press the **Page** Key, the FFD will return to normal operation and the 20/20 displays the newly configured page.

## 5.4 HALCYON DISPLAY

The Halcyon Display is a dedicated electronic compass display which may be connected to your HS 2000 System in a similar manner to an FFD. The display provides clear and accurate digital indication of compass heading information together with a bar graph indicating port and starboard off-course error relative to a set course. The display area is split into three. The three large digits in the upper left part always show compass heading.

A bar graph indicator, below the compass heading display, will show deviation from the set course as segments of bar graph to the left or right of the zero centreline. This provides an immediate indication of the vessel being off-course to port or starboard. This off course value is also shown numerically below this display.

Four rows of text are provided down the right-hand side of the display. Each row is associated with the adjacent key and indicates the selected operating function and the various settings.

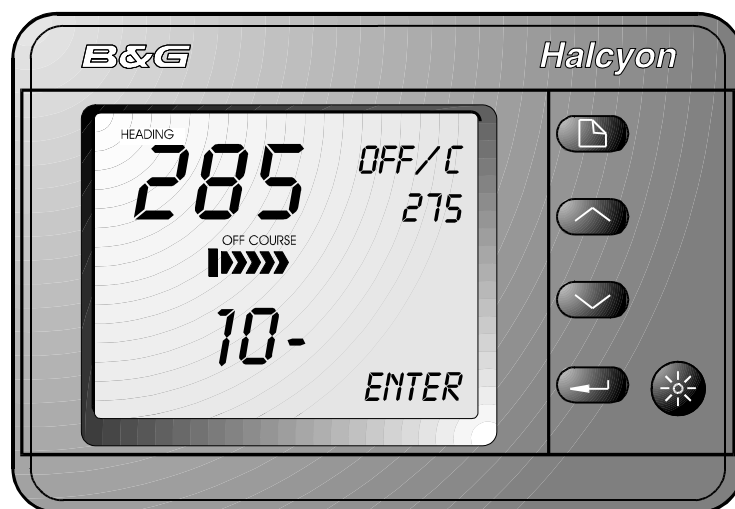

Fig 5.2 - Halcyon Display

### 5.4.1 The Keys

The Halcyon Display is provided with the following five keys:

- Power/Lights Key
- Page Key
- Scroll Up Key
- Scroll Down Key
- Enter Key

### 5.4.2 Power/Lights Key

The Power/Lights Key is operated in an identical manner to the Power/Lights Keys provided on the FFDs. See Part 2 - Operating Information.

### 5.4.3 Page Key

Successive pressing of the **Page** Key will access the following three functions in a fixed order:

- ?? Off Course
- ?? Stored Course
- ?? Turn Rate

### 5.4.4 Operating Mode Selection

The Halcyon Display has been designed for use with both sail and powered craft. The operational functions differ slightly depending on the choice of operating mode. These modes are:

- ?? Sail Boat
- ?? Cruise Power
- ?? Race Power

To select the desired operating mode (Cruise Power), observe the following procedure:

- (1) Press the **Page** key repeatedly until the display shows SETUP.
- (2) Press the **Scroll Up** key until the display shows OP MODE.

(3) Press the **Scroll Down** key until the display shows POWER BOAT.

(4) Press the **Page** key to exit the setup mode.

The Halcyon Display has now been configured for Cruise Power operation.

#### 5.4.5 Off Course Function

The Off Course function provides the helmsman with accurate Off Course information to assist in steering a steady and accurate course.

Off Course is calculated by comparing the vessel's current heading with a previously set reference heading. The deviation is shown by the bar graph and numerically as degrees port or starboard.

The bar graph scale shows one segment for every 2° off course up to 10°, then one segment for every 5° up to 20°. If the current heading is the same as the desired heading then only the central segment will be shown. The numeric display will show 00.

The Off Course function may be reset by pressing the **Enter** Key, operation of a Remote Push-button if fitted or from any FFD. Pressing the **Enter** Key or Remote Push-button will select the current heading as the reference heading.

Any deviation from this new course will be shown on the bar graph and the numerical display. To reset the off course function from an FFD, select the NAVIGATE Menu and then OFF CRSE as described in Part 2 - Operating Information.

#### 5.4.6 Stored Course Function

Up to 10 preset courses, numbered CRS 1 to CRS 10, may be stored at any one time. When the Stored Course function is selected by operation of the **Page** Key the display changes to show the selected course number with the value immediately below. All courses are retained in the Halcyon Display memory during power off so that the desired courses may be entered prior to departure.

To select a specific course number proceed as follows:

- (1) Select the Stored Course Function by successive presses of the **Page** Key until the display shows the Stored Course Function.
- (2) Press **Scroll Up** and CRS 1 will flash.
- (3) Using the **Scroll Up** and/or **Scroll Down** Keys select the course (CRS) number required.
- (4) Press the **Enter** Key to enter the selected course as the reference.

To change the value of any stored course proceed as follows:

- (1) Select the Stored Course Function by successive presses of the **Page** Key until the display changes to show the Stored Course Function.
- (2) Press the **Scroll Down** Key and the stored value of the course selected will flash.
- (3) Using the **Scroll Up** and **Scroll Down** Keys change the value to the new course.
- (4) Press the **Enter** Key to enter the new course.

#### **5.4.7 Turn Rate Function**

The turn rate function displays the vessel's rate of turn in degrees to port or starboard. There are two ways of displaying this, either as a mean rate of turn or as an instantaneous rate of turn in degrees per second.

#### **5.4.8 Mean Rate**

Whenever the turn rate function is selected using the PAGE key, the mean rate of turn is displayed. The MEAN legend is shown on the display.

The present heading is compared with a continually updated heading and displayed graphically and numerically as degrees to port or starboard. This will give a trend to the right or left of the average heading. Hence, if the heading fluctuates both to port and starboard, but with a bias to port, then a net trend to port will be displayed. Similarly for a starboard trend.

### 5.4.9 Instantaneous Rate

While the Halcyon Display is showing the vessel's mean rate of turn, press the **Scroll Down** key, the DEG/S legend is shown to indicate rate of turn displayed as degrees per second. The centre analogue bar graph will now show the instantaneous rate of turn to port or starboard.

#### Note

This is a useful feature when performing an automatic compass swing on the Halcyon 2000 Compass, where it is necessary to maintain a suitably slow and steady rate of turn. If the rate is kept between 1 and 3 deg/s, a satisfactory calibration should be achieved.

## 5.5 HALCYON 2000 COMPASS

The Halcyon 2000 Compass is a high performance electronic transmitting compass which interfaces directly with your HS 2000 System. Heading and direction information may be selected for display on any of the FFDs or on a Halcyon Display. In addition analogue compass card type displays may be added if your system has the optional Wind Board (402-10-005) PCB fitted.

Software incorporated within the Halcyon 2000 Compass allows the unit to learn the magnetic fields in the vessel which may cause deviation errors. These errors can be reduced to an insignificant level by following the Calibration procedure described in Part 3.

## PART 6 - DIAGNOSTIC DATA

### CONTENTS

<b>Para</b>		<b>Page</b>
6.1	FFD DIAGNOSTICS	6-3
6.1.1	Diagnostic Function Selection	6-3
6.1.2	Key Test	6-3
6.1.3	Display	6-4
6.1.4	Network	6-4
6.1.5	RAM	6-4
6.1.6	PROM	6-4
6.1.7	EPROM	6-4
6.1.8	Lighting	6-5
6.1.9	Debug	6-5
6.1.10	RES-SYS	6-5
6.1.11	Versions	6-5
6.1.12	Errors	6-6
6.1.13	Remote	6-6
6.2	DEPTH SOUNDER	6-6
6.2.1	Boat Stationary	6-7
6.2.2	Boat Moving	6-8
6.2.3	Consistently Shows Shallow Depth	6-9
6.2.4	Random Deep Depths	6-9
6.3	ERROR MESSAGES	6-10
6.4	HALCYON 2000 COMPASS	6-11
6.4.1	Shows Heading and CAL Flashing	6-11
6.4.2	Heading Shows ERR	6-11
6.4.3	Heading or COMP CAL Shows PHS	6-11
6.4.4	Two Headings Flashing Alternately	6-12
6.4.5	True Wind Direction, Tide Set or DR Course Not Functioning Correctly	6-12
6.5	NMEA ALPHABETICAL INDEX	6-13
6.5.1	NMEA Input Summary	6-13
6.5.2	NMEA Output Summary	6-14

**Intentionally Left Blank**

## PART 6 - DIAGNOSTIC DATA

### 6.1 FFD DIAGNOSTICS

The FFD program contains a number of diagnostic functions which allow the FFD keys, display and memory to be tested, and also performs checks on other components of the system via the network. One of the more useful of these tests enables the user to determine the software version numbers of the processor units in the system. This information is useful when liaising with Service Agents.

#### 6.1.1 Diagnostic Function Selection

The diagnostic functions are selected as follows:

- (1) When switching on the system press **Enter** until DIAGNOST appears in the upper text window.
- (2) Press **Enter** again, the first Test option KEYTEST appears.
- (3) The required test is then selected using the **Scroll Up** and **Scroll Down** Keys.
- (4) Press **Enter** to start the required test.
- (5) On completion of each test press **Scroll Up** or **Scroll Down** to scroll to the next test. Press **Enter** to start the test.
- (6) To return the display back to normal operation press the **Page** Key.
- (7) Provided that the power is not switched off or a system reset is not performed, the diagnostics can be re-entered by holding **Enter** down and pressing the On/Off Lights Key.

The options available from the DIAGNOSTICS Menu are described in Paragraphs 6.1.2 to 6.1.13.

#### 6.1.2 Key Test

The display requests the user to press each key in turn as follows:

Key 1	Enter
Key 2	Scroll Down
Key 3	Scroll Up
Key 4	Page
Key 5	On/Off Illumination
Key 6	Speed/Depth
Key 7	Wind
Key 8	Navigation

If the key operation is not detected after a short interval then the message TIME OUT is displayed.

### **6.1.3 Display**

The **Scroll Up** Key can be used to step the display through a sequence that switches ON single segments in all characters, blanks the display and switches ON all segments. When all segments are switched ON, 16 characters are displayed at the top and bottom of the display. For the remainder of the test and in normal operation only 10 characters are used since the unused segments are connected together. To stop the display test press the **Enter** Key.

### **6.1.4 Network**

This option tests part of the FFD's circuitry for communicating on the network. At the end of the test the display will show either PASS or, when failed, a value.

### **6.1.5 RAM**

This option tests for correct operation of the FFD's internal Random Access Memory (RAM). RAM PASS OK is displayed to indicate satisfactory completion of the test. If the test fails, RAM FAIL is displayed and correct operation of the unit cannot be guaranteed.

### **6.1.6 PROM**

This option tests for correct operation of the FFD's program memory, and calculates a checksum by adding the individual bytes of memory together. The total is displayed in hexadecimal code in the bottom half of the display, with the two least significant digits indicating the software version number. If this test fails then FATAL ER 02 is displayed. The upper half of the display shows the FFD's network node number.

### **6.1.7 EPROM**

This option tests the correct operation of the FFD's non-volatile memory where the display settings are stored when power is switched off. If this fails FATAL ER 03 or FATAL ER 04 will be displayed. The display page configuration and possibly the text for some functions will be lost.

### 6.1.8 Lighting

This option checks for correct operation of the display lighting control.

### 6.1.9 Debug

**CAUTION: This test is not for normal use, since it may seriously affect the operation of the HS 2000 System.**

This option is used for accessing memory in other units in the system.

### 6.1.10 RES-SYS

**CAUTION: Do not use this option during normal operation as the system will give inaccurate results until re-calibrated.**

This option allows either individual units or the entire system to be reset. The network node address of the unit to be reset is selected using the **Scroll Up** and **Scroll Down** Keys and then pressing **Enter**. The node allocations are as follows:

01 - Depth Board	05 - Wind Board
09 - NMEA Interface	0D - Expansion Board
FF - Entire System	

#### Note

FFD software prior to 3B is unable to reset individual units. When the system is reset, all calibration, damping and alarm values will return to default settings and all log values and trip functions will reset to zero, all display units will reset to the default page settings. After a delay of approximately 20 seconds the system should be switched OFF and then ON, twice, to complete the reset procedure. This is necessary as some of the units are automatically re-configured depending on which other units are connected to the network.

### 6.1.11 Versions

This option allows the user to ascertain the software version numbers for the FFD (DISPLAY) and Depth Sounder (DEPTH). When VERSIONS is displayed flashing on the screen, press **Enter**, use the **Scroll Up** Key to select the required version number. Press **Enter** to display the software checksum of the appropriate unit in the lower display. The two least significant digits of the checksum indicate the software version number.

### 6.1.12 Errors

This option is primarily used to interrogate the HS 2000 network and is designed for use by service technicians to ascertain levels of interference that may be present, for example, interference may be induced by an SSB transmitter or radar. The display shows the number of messages that have not been transmitted correctly in the first instance; between 10 and 20 errors per minute is quite normal. A higher number of errors can indicate that the network terminators are incorrectly fitted.

### 6.1.13 Remote

This option allows the user to invoke internal RAM, PROM and basic network checks for any remote processor node connected to the network, and display the appropriate error messages on the FFD. Node numbers are allocated when the system is first switched ON or following a system reset. In a system comprising a main processor and performance unit alone, the node numbers will be:

Depth board	1
Wind board	5

In a system with additional processor nodes it may be necessary to determine the individual node numbers by disconnecting nodes in turn, and running the remote PROM test. If no pass or fail message is displayed within 10 seconds, it can be assumed that the node under test is not part of the system. The REMOTE tests for the currently selected node can be exited by holding **Enter** down and pressing the **On/Off Illumination** Key.

## 6.2 DEPTH SOUNDER

Fault finding on the Depth Sounder is often difficult since depth sounder performance is dependent on many factors, including: transducer type and installation, boat speed, electrical noise, sea state, sea bed conditions, air and plankton in the water. Indications of problems with the Depth Sounder normally manifest themselves in one of three ways:

The display shows:

-  
- -  
-

The display locks down showing depths in the range 0 to 1.5m or display shows random deep depths.

All of these symptoms can be caused by external conditions, so care and additional tests should be performed before concluding that the fault lies with the Depth Sounder. Two Depth Sounder parameters which can assist in diagnosing faults are measurements of receiver gain and noise; these can be found in the PARAMTR Menu on any FFD.

### 6.2.1 Boat Stationary

**Symptom:** Display consistently shows:

-  
- -  
-

when comfortably within the range of the Depth Sounder when the boat is stationary in the water; this indicates that no consistent signal is being received by the Depth Sounder.

**Possible causes:**

- (a) The transducer is not connected.
- (b) The transducer is not stowed in the housing.
- (c) If sounding through the hull, there is not enough oil in the housing, or the hull material is unsuitable for conduction of sound.
- (d) The transducer is faulty or has been damaged. The transducer should be checked for any damage, barnacle growth or thick layers of paint. If the transducer requires cleaning, a scrubbing brush should be used. The face of the transducer may have a thin coat of anti-fouling applied, ensuring that no air bubbles are trapped in the paint. The cable should be checked for damage; the resistance between the two orange wires should be in the range 0.5 to 5 Ohms, and resistance between the screen and the cores should be infinity. Resistance measurements should only be made with the transducer disconnected from the Processor Unit.
- (e) The gain of the receiver has been set too low. It is possible to adjust the maximum gain via CAL VAL1 on gain; this is normally set to 30 and should not be adjusted.

## 6.2.2 Boat Moving

**Symptom:** Display shows:

-  
- -  
-

when boat is moving; this is most often an indication of difficult sounding conditions, but can also indicate a badly positioned transducer.

### **Possible causes:**

(a) Difficult sounding conditions and/or Depth Sounder unable to track rapidly changing bottom. If entering shallow water, the boat should slow down and proceed with caution.

(b) Aeration in the water. Most often caused by the wake of another vessel and can persist in the water for a long period after the passing of the vessel. In some instances the Depth Sounder will indicate the depth of the aeration layer caused by a large vessel.

(c) Poorly sited transducer. Determine which conditions are causing the problem; this is best achieved by completing some maneuvering trials in an area which has: a relatively uniform depth, a solid bottom and is clear of the wake from other boats.

First, determine the maximum speed at which reliable soundings can be made when traveling in a straight line. Then repeat the tests when turning to port and starboard. If better results can be obtained when turning it is possible that there is something in front of the transducer causing aeration. This may be a rubbing strake or other hull fitting, such as a water outlet; in which case the transducer or the hull fitting should be re-sited.

If there seems to be little difference whether turning or not, the position of the transducer should be reviewed. The transducer may be coming out of the water at high speed or in rough water. It is impossible to give specific instructions on where to re-site the transducer since it is dependent upon the design of boat; generally better results will be obtained nearer the centre line of the boat. If there is only a problem when heeled, fitting two transducers with a changeover switch should be considered.

### 6.2.3 Consistently Shows Shallow Depth

**Symptom:** Display consistently shows a shallow depth between 0 and about 1.5m.

**Possible causes:**

(a) Faulty transducer. The transducer rings for too long after the transmit pulse is sent and the ringing is interpreted as a shallow return by the Depth Sounder. On a deep keeled boat it may be possible to overcome this problem by increasing the minimum depth to just less than the draft of the yacht. The minimum depth is adjusted by changing CAL VAL1 on NOISE.

PARAMTR? NOISE, **CALBRATE? CAL VAL1 (MIN DPTH M)**

The default setting for minimum depth is 0.7 metres.

(b) Keel echoes. If the transducer has been installed too close to a deep keel, it is possible that consistent echoes from the keel are being received. The transducer should be re-sited further away from the keel. If this is not possible, increasing the minimum depth to just below the keel can solve the problem but may result in poor performance when the bottom is shaded by the keel. Marginal cases are sometimes caused by side lobes from the transducer main beam and may be rectified by rotating the transducer in the housing.

(c) Following or crossing the path of another vessel which has left an aerated layer in the water.

### 6.2.4 Random Deep Depths

**Symptom:** Display shows random deep depths.

**Possible causes:**

(a) Electrical noise. The Depth Sounder incorporates circuits and software to reduce the susceptibility to electrical noise, however, this can still present problems if not installed carefully, or other equipment is incorrectly suppressed. The Depth Sounder measures the ambient noise which can be displayed by viewing the PARAMTR Menu. When the boat is stationary, electrical equipment should be switched ON and OFF, in turn, while viewing the depth and noise displays to try and determine the source of the problem.

(b) Acoustic Interference. Other depth sounders and sonar can cause problems, however, in all likelihood this

will only occur when other boats are in the close vicinity, for example, when moored alongside in a crowded marina. Furthermore, acoustic noise can be generated by water flow past the transducer and other items of mechanical machinery.

(c) Mid-water echoes. When outside the range of the Depth Sounder, it is possible that random depths are displayed due to mid-water echoes from shoals of fish or aeration layers.

### 6.3 ERROR MESSAGES

Error messages are defined as follows:

- (a) Er01 Error detected reading the analogue to digital converter on the Depth Sounder board. This can indicate a fault on the board, or that the sea water temperature or compass signals are outside the normal range; try disconnecting the sensors in turn.
- (b) Er02 Error detected when writing to the analogue to digital converter on the Depth Sounder board. This can indicate the same problems as Er01.
- (c) Err.3 Syntax or parity error on received NMEA data.
- (d) Err.4 Checksum error on received NMEA 0183 data.
- (e) CAL Alternating with a function value indicates that the value has yet to be calibrated. This will occur following a system reset, or if the internal battery is exhausted.
- (f) NO SPACE FFD memory full, too many functions have been declared.
- (g) NOT FOUND New function declared without text.

## 6.4 HALCYON 2000 COMPASS

### 6.4.1 Shows Heading and CAL Flashing

**Symptom:** Display flashes a Heading and CAL

**Possible Causes:**

(a) The memory in the Halcyon 2000 is empty or has been corrupted. This may be due to a System Reset being performed or the first time the compass has been installed and not yet been calibrated. Perform a calibration swing to restore normal operation.

(b) After a calibration swing the result is always **FAIL**. There is a source of magnetic deviation near to the Halcyon 2000 compass. Try re-positioning the compass and perform the calibration.

### 6.4.2 Heading Shows Err

**Possible Causes:**

(a) The signal from the fluxgate sensor is too big or too small. Try re-positioning the compass. If still showing **Err** set NAVIGATE? COMP CAL, CAL VAL 2 (**RES CAL**) to 1. This will reset the compass (see 4). All previous calibrations will be lost.

### 6.4.3 Heading or COMP CAL Shows PHS

**Possible Causes:**

(a) The compass is in the middle of resetting, the display should show heading and CAL flashing after 20 seconds. A calibration swing will be required.

#### **6.4.4 Two Headings Flashing Alternately**

**Symptom:** Pilot or Halcyon Displays shows 2 headings flashing alternately

**Possible Causes:**

(a) The Pilot has not been set to use the Halcyon 2000 as it's heading source. See using Halcyon 2000 with a B&G ACP Pilot. If the Halcyon 2000 is not to be the source of heading then it must be unplugged from the network.

#### **6.4.5 True Wind Direction, Tide Set or DR Course Not Functioning Correctly**

(a) The Main Processor has not been set to use the Halcyon 2000 as the heading source. Set NAVIGATE? COURSE, CAL VAL 1 (**HDG NODE**) to 16.

## 6.5 NMEA ALPHABETICAL INDEX

### 6.5.1 NMEA Input Summary

APA	Autopilot format A
APB	Autopilot format B
BEC	Bearing and distance to waypoint, great circle, dead reckoned
BER	Bearing and distance to waypoint, rhumb, dead reckoned
BOD	Bearing to destination waypoint from origin waypoint
BWC	Bearing and distance to waypoint, great circle measured
BWR	Bearing and distance to waypoint, rhumb measured
BWW	Bearing to waypoint from waypoint
GGA	Global Positioning System fix data
GLL	Latitude and Longitude (NMEA Versions 1.5 and 2.0)
GLP	Loran C present fix
HDM <sup>1</sup>	Present heading, ?Magnetic
HDT <sup>2</sup>	Present heading, ?True
HSC <sup>3</sup>	Heading, steering
HVD	Magnetic variation, automatic
HVM	Magnetic variation, manually set
MTA	Air temperature, ?Centigrade
MTW	Sea temperature, ?Centigrade
RMA	Recommended minimum specific, Loran C data
RMB	Recommended minimum navigation information
RMC	Recommended minimum specific GNSS (GPS) data
VHW	Water speed and heading
VTG	Course Over Ground (COG) and Speed Over Ground (SOG)
WBD	Bearing and distance to waypoint
WCV	Waypoint closure velocity
WDC	Distance to waypoint, great circle
WDR	Distance to waypoint, rhumb
XTE	Cross track error, measured
XTR	Cross track error, dead reckoned
ZDL	Time and distance to layline
ZLZ	Time of day
ZTG	Time to waypoint

### Notes

1. Function repeated when no B&G fluxgate connected to system. Not used by HS 2000 autopilot.
2. Displayed when no B&G fluxgate connected to system. Can be used by HS 2000 autopilot.
3. Re-transmitted only. Not used by HS 2000.

## 6.5.2 NMEA Output Summary

DBT	Depth below transducer
GLL <sup>1</sup>	Geographic position, Latitude and Longitude
HDM	Present heading, ?Magnetic
HDT <sup>1</sup>	Present heading, ?True
HSC <sup>1</sup>	Heading steering command
MTA	Air temperature, ?Centigrade
MTW	Sea temperature, ?Centigrade
MWD <sup>2</sup>	Surface wind direction and velocity
MWV <sup>2</sup>	Wind speed and angle
VHW	Water speed and heading
VLW	Log mileage, water referenced
VPW <sup>2</sup>	Velocity parallel to true wind, device measured (VMG)
VTG <sup>1</sup>	Course Over Ground (COG) and Speed Over Ground (SOG)
VWR <sup>2</sup>	Wind relative bearing and velocity
VWT <sup>2</sup>	Wind true bearing and velocity
XTE <sup>1</sup>	Cross track error, measured

### Notes

1. Repeated NMEA sentence from NMEA input
2. Sentence output if appropriate Wind Board and 213 wind sensor connected

## A1 HS 2000 CALIBRATION DATA

### A1.1 HS 2000 Settings Table

Function	Calibration Type / Unit	Calibration Value	Damping Value	Alarm	Alarm Value
BOAT SPD STD LOG	Single Hz/Knot			High	
				Low	
DEPTH	Datum Offset m, ft or fms			High	
				Low	
HEADING	Alignment?			Sector	
	Node				
SEA TEMP	Sensor Type			High	
	Offset Temp (°C or °F)			Low	
TIDE SET	Magnetic Variation				